

Service Manual

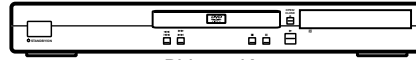

DV-454-K

ORDER NO.
RRV2610

DVD PLAYER

DV-454-K

DV-454-S

THIS MANUAL IS APPLICABLE TO THE FOLLOWING MODEL(S) AND TYPE(S).

| Model | Type | Power Requirement | Regional restriction codes (Region No.) | Remarks |
|----------|-----------|-------------------|-----------------------------------------|---------|
| DV-454-K | WYXU | AC220-240V | 2 | |
| DV-454-K | WYXU/FRGR | AC220-240V | 2 | |
| DV-454-K | WVXU | AC220-240V | 2 | |
| DV-454-S | WYXU | AC220-240V | 2 | |
| DV-454-S | WYXU/FRGR | AC220-240V | 2 | |
| DV-454-S | WVXU | AC220-240V | 2 | |

Confirm it

Serial No.

○○XU: □□PG#####△△



For details, refer to "Important symbols for good services".

SAFETY INFORMATION



This service manual is intended for qualified service technicians ; it is not meant for the casual do-it-yourselfer. Qualified technicians have the necessary test equipment and tools, and have been trained to properly and safely repair complex products such as those covered by this manual. Improperly performed repairs can adversely affect the safety and reliability of the product and may void the warranty. If you are not qualified to perform the repair of this product properly and safely, you should not risk trying to do so and refer the repair to a qualified service technician.

WARNING !

THE AEL (ACCESSIBLE EMISSION LEVEL) OF THE LASER POWER OUTPUT IS LESS THAN CLASS 1 BUT THE LASER COMPONENT IS CAPABLE OF EMITTING RADIATION EXCEEDING THE LIMIT FOR CLASS 1.

A SPECIALLY INSTRUCTED PERSON SHOULD DO SERVICING OPERATION OF THE APPARATUS.

LASER DIODE CHARACTERISTICS

FOR DVD : MAXIMUM OUTPUT POWER : 5 mW
WAVELENGTH : 650 nm
FOR CD : MAXIMUM OUTPUT POWER : 5 mW
WAVELENGTH : 780 nm

LABEL CHECK

CAUTION : VISIBLE AND INVISIBLE LASER RADIATION WHEN OPEN. AVOID EXPOSURE TO BEAM.
VORSICHT : SICHTBARE UND UNSICHTBARE LASERSTRAHLUNG, WENNABDECKUNG GEÖFFNET NICHT DEM STRAHL AUSSETZEN!
ADVARSEL : SYNLIG OG USYNLIG LASERSTRÅLING VED ÅBNING UND GÅ UDSÆTTELSE FOR STRÅLING.
VARNING : SYNLIG OCH OSYNLIG LASERSTRÅLNING NÄR DENNA DEL ÄR ÖPPNAD BETRÄKTA EJ STRÅLEN.
VARO! : AVATTAESSA ALTI TISTUT NÄKYVÄ JA NÄKYMÄTTÖMÄLLE LASERSATEIL YLLE. ÄLÄ KATSO SÄTEESEEN.
CAUIDADO : RADIACIÓN LASER VISIBLE E INVISIBLE AL ESTAR ABIERTO. EVITAR EXPOSICIÓN AL RAYO.

VRW1872

**CLASS 1
LASER PRODUCT**

(Printed on the Rear Panel)

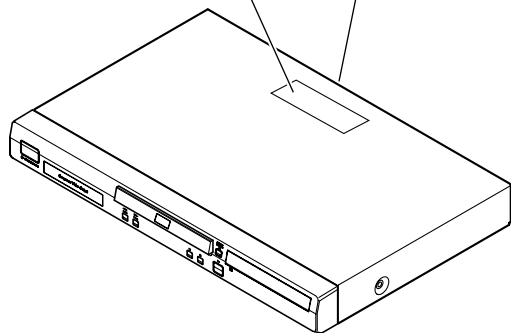

Additional Laser Caution

1. Laser Interlock Mechanism

- Loading switch (S101 on the LOAB Assy) is used for interlock mechanism of the laser.

When this switch turned ON in SW2 (XCLOSE) side (OPEN signal is 0V and XCLOSE signal is 3.5V), a laser becomes the status which can completely oscillation.

Furthermore, the laser completely oscillates in the disc judgment and disc playback.

When player is power ON state and laser diode is not completely oscillating, 780nm laser diode is always oscillating by half power.

- Laser diode is driving with Q101 (650nm LD) and Q102 (780nm LD) on the FJMB Assy.

Therefore, when short-circuit between the emitter and collector of these transistors or the base voltage is supplied for transistors turn on, the laser oscillates. (failure mode)

- In the test mode *, there is the mode that the laser oscillates except for the disc judgment and playback. LD ON mode in the test mode oscillates with the laser forcibly.

The interlock mechanism mentioned above becomes invalid in this mode.

2. When the cover is open, close viewing through the objective lens with the naked eye will cause exposure to the laser beam.

* : See page 53.

[Important symbols for good services]

In this manual, the symbols shown-below indicate that adjustments, settings or cleaning should be made securely. When you find the procedures bearing any of the symbols, be sure to fulfill them:

1. Product safety



You should conform to the regulations governing the product (safety, radio and noise, and other regulations), and should keep the safety during servicing by following the safety instructions described in this manual.

2. Adjustments



To keep the original performances of the product, optimum adjustments or specification confirmation is indispensable. In accordance with the procedures or instructions described in this manual, adjustments should be performed.

3. Cleaning



For optical pickups, tape-deck heads, lenses and mirrors used in projection monitors, and other parts requiring cleaning, proper cleaning should be performed to restore their performances.

4. Shipping mode and shipping screws



To protect the product from damages or failures that may be caused during transit, the shipping mode should be set or the shipping screws should be installed before shipping out in accordance with this manual, if necessary.

5. Lubricants, glues, and replacement parts



Appropriately applying grease or glue can maintain the product performances. But improper lubrication or applying glue may lead to failures or troubles in the product. By following the instructions in this manual, be sure to apply the prescribed grease or glue to proper portions by the appropriate amount. For replacement parts or tools, the prescribed ones should be used.

Discs compatible with this player

Any disc that displays one of the following logos should play in this player. Other formats, including DVD-Audio, DVD-RAM, DVD-ROM, CD-ROM (except those that contain MP3 files), SACD and Photo CD will not play.



DVD-Video



Audio-CD



Video-CD



CD-R



CD-RW

CONTENTS

| | | |
|---|----------------------------------------------------|----|
| A | 1. SPECIFICATIONS | 5 |
| | 2. EXPLODED VIEWS AND PARTS LIST | 6 |
| | 2.1 PACKING | 6 |
| | 2.2 EXTERIOR SECTION | 8 |
| | 2.3 LOADING MECHANISM ASSY | 10 |
| | 2.4 TRAVERSE MECHANISM ASSY-S | 14 |
| | 3. BLOCK DIAGRAM AND SCHEMATIC DIAGRAM | 16 |
| | 3.1 BLOCK DIAGRAM | 16 |
| | 3.1.1 SIGNAL ROUTE | 16 |
| B | 3.1.2 POWER SUPPLY BLOCK | 18 |
| | 3.1.3 WAVEFORMS | 19 |
| | 3.2 LOAB ASSY and OVERALL WIRING DIAGRAM | 20 |
| | 3.3 FJMB ASSY 1/5 [FRONT END BLOCK] | 22 |
| | 3.4 FJMB ASSY 2/5 [BACK END BLOCK] | 24 |
| | 3.5 FJMB ASSY 3/5 [AUDIO BLOCK] | 26 |
| | 3.6 FJMB ASSY 4/5 [VIDEO BLOCK] | 28 |
| | 3.7 FJMB ASSY 5/5 [FL CONTROL BLOCK] | 30 |
| | 3.8 IRKY and PSWB ASSYS | 32 |
| | 3.9 POWER SUPPLY UNIT (VWR1352) | 34 |
| C | 3.10 POWER SUPPLY UNIT (VWR1354) | 35 |
| | 3.11 SCRIB ASSY | 36 |
| | 4. PCB CONNECTION DIAGRAM | 39 |
| | 4.1 LOAB ASSY | 39 |
| | 4.2 FJMB ASSY | 40 |
| | 4.3 IRKY and PSWB ASSYS | 44 |
| | 4.4 POWER SUPPLY UNIT (VWR1352) | 45 |
| | 4.5 POWER SUPPLY UNIT (VWR1354) | 46 |
| | 4.6 SCRIB ASSY | 47 |
| | 5. PCB PARTS LIST | 48 |
| D | 6. ADJUSTMENT | 51 |
| | 6.1 ADJUSTMENT ITEMS AND LOCATION | 51 |
| | 6.2 JIGS AND MEASURING INSTRUMENTS | 51 |
| | 6.3 NECESSARY ADJUSTMENT POINTS | 52 |
| | 6.4 TEST MODE | 53 |
| | 6.5 MECHANISM ADJUSTMENT | 54 |
| | 7. GENERAL INFORMATION | 57 |
| | 7.1 DIAGNOSIS | 57 |
| | 7.1.1 TEST MODE | 57 |
| E | 7.1.2 DISPLAY OF THE MECHANISM ERROR HISTORY | 63 |
| | 7.1.3 TEST POINTS LOCATION & WAVEFORMS | 66 |
| | 7.1.4 TROUBLE SHOOTING | 71 |
| | 7.1.5 SEQUENCE AFTER THE POWER ON | 73 |
| | 7.1.6 DISASSEMBLY | 74 |
| | 7.2 IC | 79 |
| | 7.3 CLEANING | 97 |
| | 8. PANEL FACILITIES | 98 |
| F | | |

1. SPECIFICATIONS

General

System DVD-Video, Video CD
 CD and MP3 files
 Power requirements.... AC 220–240V, 50/60 Hz
 Power consumption.....14 W
 Power consumption (standby)..... 0.3W
 Weight 2.5 kg
 Dimensions
 DV-454420 (W) x 55 (H) x 278 (D) mm

Operating temperature.....+5°C to +35°C
 Operating humidity5% to 85%
 (no condensation)

S-Video output

Y (luminance) - Output level.....1 Vp-p (75Ω)
 C (color) - Output level..... 286 mVp-p (75Ω)
 Jack S-Video jack

Video output

Output level1 Vp-p (75Ω)
 Jack RCA jack

AV connector output

AV Connectors (21-pin connector assignment)
 AV connector input/output 21-pin connector
 This connector provides the video and audio signals for connection to a compatible colour TV or monitor.

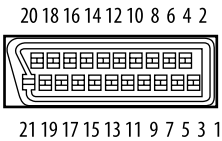

| | |
|----------|--------------------|
| PIN no. | |
| 1 | Audio 2/R out |
| 3 | Audio 1/L out |
| 4 | GND |
| 7 | B out |
| 8 | Status |
| 11 | G out |
| 15 | R or C out |
| 17 | GND |
| 19 | Video out or Y out |
| 21 | GND |

Audio output (1 stereo pair)

Output levelDuring audio output
 200 mVrms (1 kHz, -20 dB)
 Number of channels 2
 Jacks RCA jack

Digital audio characteristics

Frequency response..... 4 Hz to 44 kHz
 (DVD fs: 96 kHz)
 S/N ratio 118 dB
 Dynamic range 101 dB
 Total harmonic distortion0.0016%
 Wow and flutter.....Limit of measurement
 (0.001%W. PEAK) or lower

Digital output

Optical digital outputOptical digital jack
 Coaxial digital output RCA jack

Accessories

| | |
|---------------------------------|---|
| Audio/video cable | 1 |
| Power cable | 1 |
| Remote control..... | 1 |
| AA/R6P dry cell batteries | 2 |
| Operating Instructions | 1 |
| Warranty card | 1 |

Note

- The specifications and design of this product are subject to change without notice, due to improvement.

• Manufactured under license from Dolby Laboratories. “Dolby” and the double-D symbol are trademarks of Dolby Laboratories.



• “DTS” is a registered trademark of Digital Theater Systems, Inc.

• TruSurround and the (●)® symbol are trademarks of SRS Labs, Inc. TruSurround technology is incorporated under license from SRS Labs, Inc.

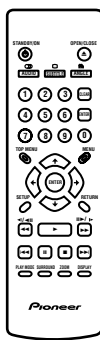
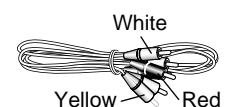
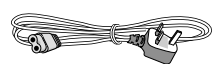
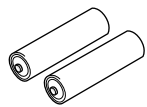
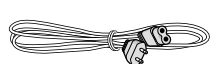
Accessories

| | | |
|---------------------------------------------------------------------------------------------------------------------|--------------------------------------------------------------------------------------------------------------------------------|--------------------------------------------------------------------------------------------------------------------------------------|
| <p>Remote Control : VXX2800</p>  | <p>Audio/Video Cable (L=1.5m): XDE3049</p>  | <p>Power Cable [WVXU Type] : ADG1156</p>  |
| | <p>AA/R6P Dry Cell Batteries</p>  | <p>Power Cable [Other Types] : ADG1154</p>  |

2. EXPLODED VIEWS AND PARTS LIST

- NOTES:
- Parts marked by "NSP" are generally unavailable because they are not in our Master Spare Parts List.
 - The  mark found on some component parts indicates the importance of the safety factor of the part. Therefore, when replacing, be sure to use parts of identical designation.
 - Screws adjacent to  mark on product are used for disassembly.
 - For the applying amount of lubricants or glue, follow the instructions in this manual. (In the case of no amount instructions, apply as you think it appropriate.)

2.1 PACKING

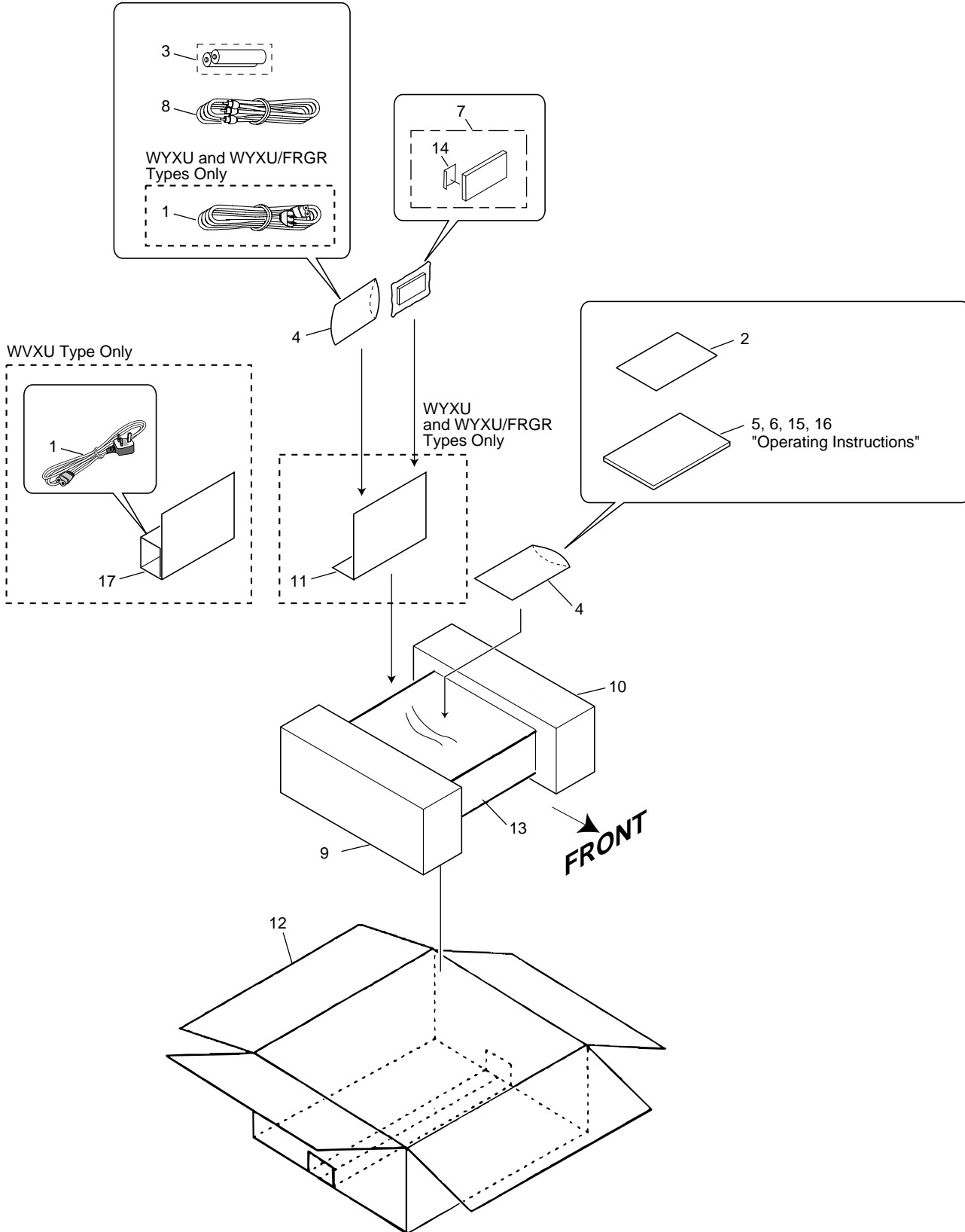

(1) PACKING PARTS LIST

| Mark | No. | Description | Part No. |
|------|-----|-----------------------------------------------|------------------------|
| ⚠ | 1 | Power Cable | See Contrast table (2) |
| NSP | 2 | Warranty Card | ARY7022 |
| NSP | 3 | AA/R6P Dry Cell Battery | VEM1030 |
| | 4 | Polyethylene Bag | VHL1051 |
| | 5 | Operating Instructions (English / Italian) | See Contrast table (2) |
| | 6 | Operating Instructions (French / German) | See Contrast table (2) |
| | 7 | Remote Control | VXX2800 |
| | 8 | Audio/Video Cable (L=1.5m) | XDE3049 |
| | 9 | Pad L | VHA1297 |
| | 10 | Pad R | VHA1298 |
| | 11 | Paper Board | See Contrast table (2) |
| | 12 | Packing Case | See Contrast table (2) |
| | 13 | Seat | Z23-007 |
| | 14 | Battery Cover | VNK4997 |
| | 15 | Operating Instructions (Spanish / Dutch) | See Contrast table (2) |
| | 16 | Operating Instructions (English) | See Contrast table (2) |
| | 17 | Accessory Box | See Contrast table (2) |

(2) CONTRAST TABLE

DV-454-K/WYXU, WYXU/FRGR, WVXU, DV-454-S/WYXU, WYXU/FRGR and WVXU are constructed the same except for the following :

| Mark | No. | Symbol and Description | Part No. | | | | | | Remarks |
|------|-----|--------------------------------------------|----------|-----------|----------|----------|-----------|----------|---------|
| | | | DV-454-K | | | DV-454-S | | | |
| | | | WYXU | WYXU/FRGR | WVXU | WYXU | WYXU/FRGR | WVXU | |
| ⚠ | 1 | Power Cable | ADG1154 | ADG1154 | ADG1156 | ADG1154 | ADG1154 | ADG1156 | |
| | 5 | Operating Instructions (English / Italian) | VRD1151 | Not used | Not used | VRD1151 | Not used | Not used | |
| | 6 | Operating Instructions (French / German) | VRD1152 | VRD1152 | Not used | VRD1152 | VRD1152 | Not used | |
| | 11 | Paper Board | VHC1089 | VHC1089 | Not used | VHC1089 | VHC1089 | Not used | |
| | 12 | Packing Case | VHG2185 | VHG2201 | VHG2181 | VHG2182 | VHG2203 | VHG2202 | |
| | 15 | Operating Instructions (Spanish / Dutch) | VRD1153 | Not used | Not used | VRD1153 | Not used | Not used | |
| | 16 | Operating Instructions (English) | Not used | Not used | VRB1286 | Not used | Not used | VRB1286 | |
| | 17 | Accessory Box | Not used | Not used | VHC1092 | Not used | Not used | VHC1092 | |

2.2 EXTERIOR SECTION

A

B

C

D

E

F

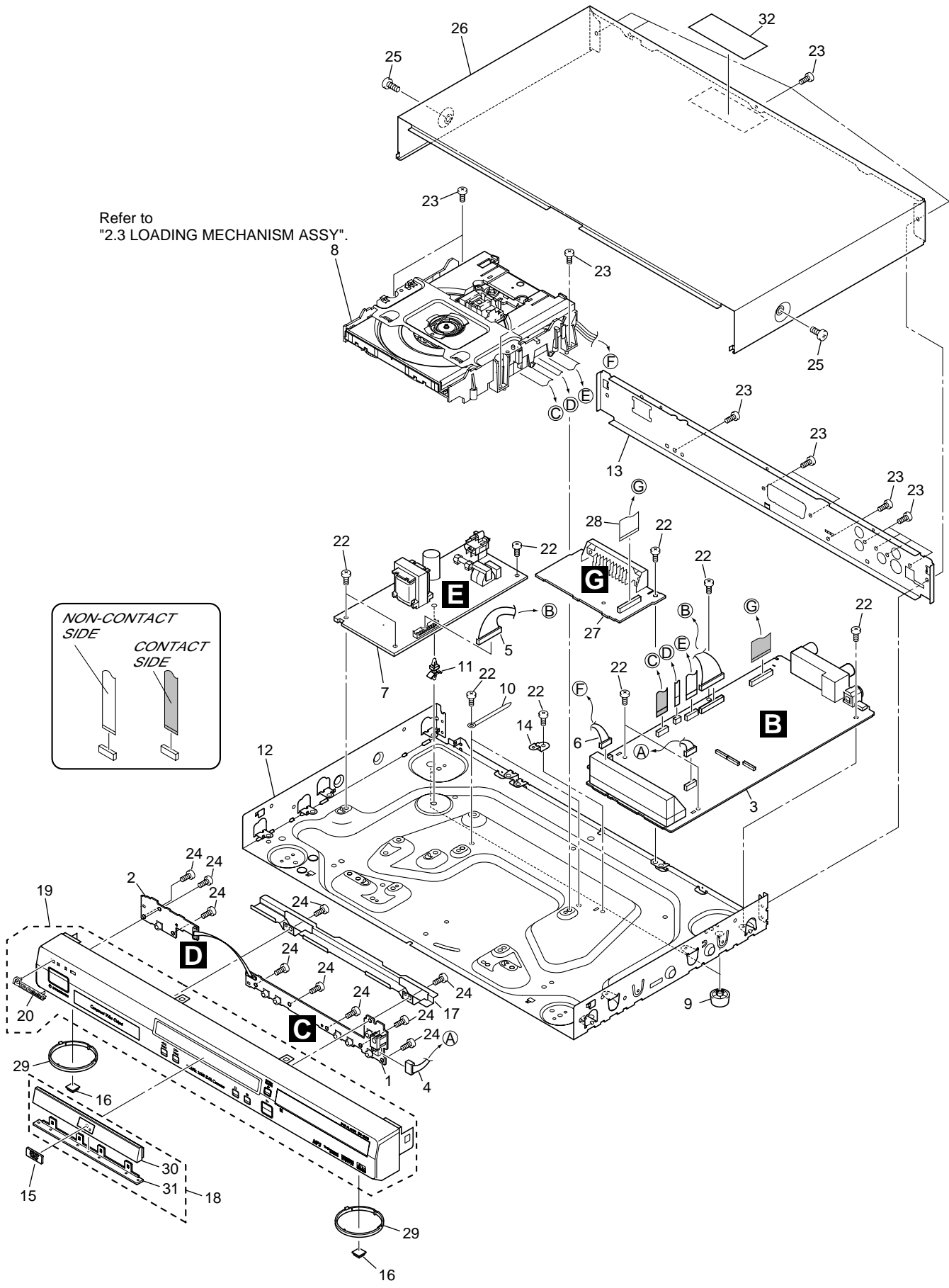

(1) EXTERIOR PARTS LIST

| Mark | No. | Description | Part No. |
|------|-----|------------------------|-------------------------|
| NSP | 1 | IRKY Assy | VWG2344 |
| NSP | 2 | PWSB Assy | VWG2345 |
| | 3 | FJMB Assy | VWS1518 |
| | 4 | Connector Assy | PF05PP-Q12 |
| | 5 | Connector Assy | PF13PP-D25 |
| | 6 | Connector Assy | PG05KK-E37 |
| △ | 7 | POWER SUPPLY Unit | VWR1354 (or VWR1352) |
| NSP | 8 | Loading Mechanism Assy | VWT1197 |
| | 9 | Leg Assy SX | AEC7113 |
| | 10 | Cord Clamper | RNH-184 |
| | 11 | Pcb Support | VEC2184 |
| NSP | 12 | Base Chassis | VNA2410 |
| | 13 | Rear Panel | See Contrast table (2) |
| | 14 | PCB Base | VNE2278 |
| | 15 | DVD V Plate | VAM1120 |
| | 16 | Rubber Foot | VEB1325 |
| | 17 | FP Angle | VNE2270 |
| | 18 | Tray Panel Assy | See Contrast table (2) |
| | 19 | Front Panel Assy | See Contrast table (2) |
| | 20 | Pioneer Badge | See Contrast table (2) |
| | 21 | ***** | |
| | 22 | Screw | BBZ30P060FMC |
| | 23 | Screw | BBZ30P080FZK |
| | 24 | Screw | BBZ30P100FZK |
| | 25 | Screw | See Contrast table (2) |
| | 26 | Bonnet Case S | See Contrast table (2) |
| | 27 | SCRB Assy | VWV1903 |
| | 28 | Flexible Cable (20P) | VDA1892 |
| | 29 | Ring | VNK4982 |
| | 30 | Tray Panel | See Contrast table (2) |
| | 31 | Sub Panel | See Contrast table (2) |
| | 32 | Label | VRW1872 |

(2) CONTRAST TABLE

DV-454-K/WYXU, WYXU/FRGR, WYXU, DV-454-S/WYXU, WYXU/FRGR and WYXU are constructed the same except for the following :

| Mark | No. | Symbol and Description | Part No. | | | | | | Remarks |
|------|-----|------------------------|----------|--------------|------|----------|-----------|--------------|---------|
| | | | DV-454-K | | | DV-454-S | | | |
| | | | WYXU | WYXU/FRGR | WYXU | WYXU | WYXU/FRGR | WYXU | |
| | 13 | Rear Panel | | VNA2441 | | | | VNA2439 | |
| | 18 | Tray Panel Assy | | VXA2514 | | | | VXA2506 | |
| | 19 | Front Panel Assy | | VXA2497 | | | | VXA2498 | |
| | 20 | Pioneer Badge | | VAM1130 | | | | VAM1129 | |
| | 25 | Screw | | BCZ40P060FZK | | | | BCZ40P060FNI | |
| | 26 | Bonnet Case S | | VXX2831 | | | | VXX2823 | |
| | 30 | Tray Panel | | VNK4976 | | | | VNK4979 | |
| | 31 | Sub Panel | | VNK5043 | | | | VNK4977 | |

2.3 LOADING MECHANISM ASSY

Note :



Refer to "Application of Lubricant".

Refer to "2.4 TRAVERSE MECHANISM ASSY-S".

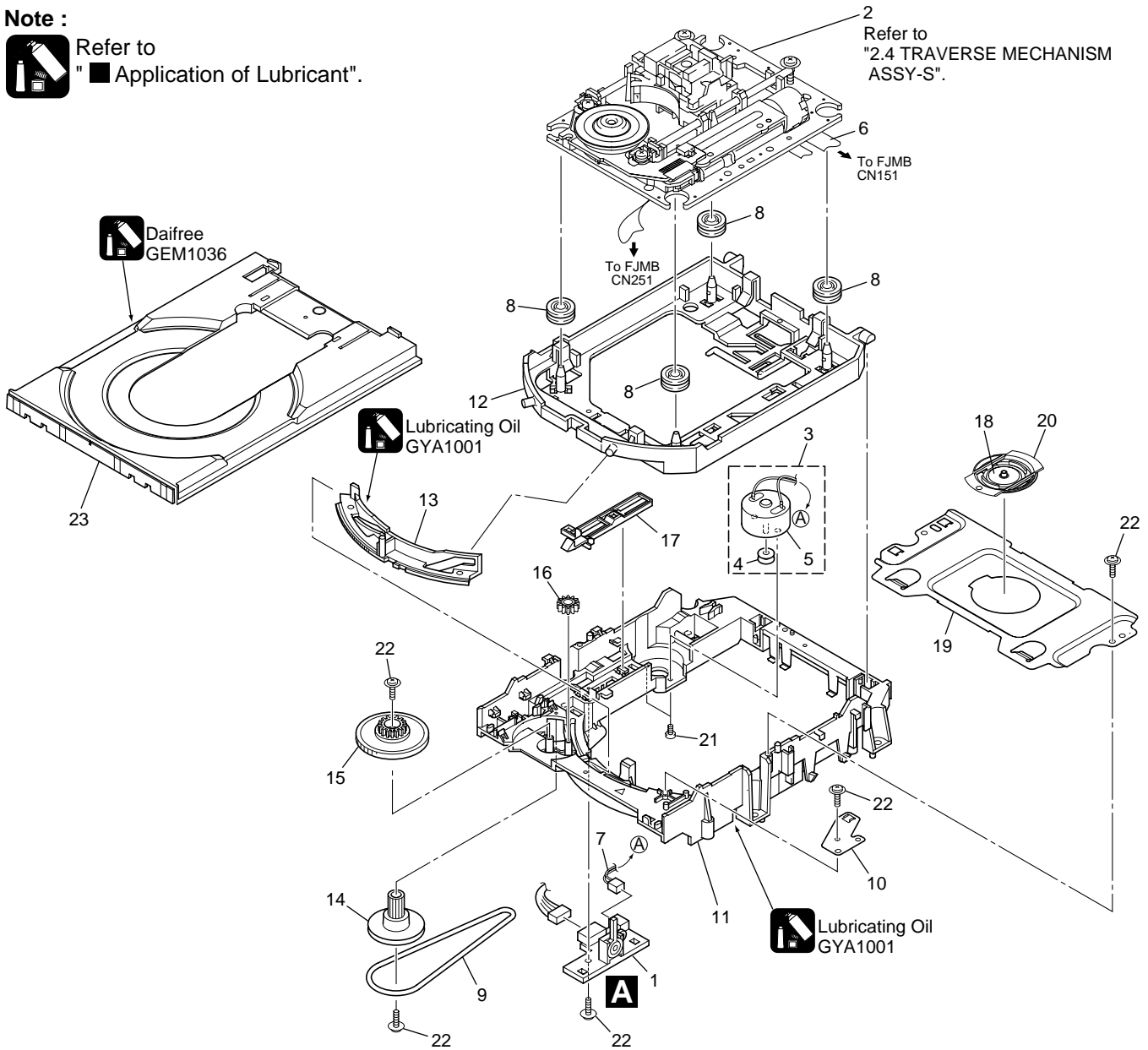

● LOADING MECHANISM ASSY PARTS LIST

| Mark | No. | Description | Part No. |
|------|-----|---------------------------|--------------|
| NSP | 1 | LOAB Assy | VWG2279 |
| | 2 | Traverse Mechanism Assy-S | VXX2782 |
| | 3 | Loading Motor Assy | VXX2505 |
| | 4 | Motor Pulley | PNW1634 |
| | 5 | Carriage DC Motor / 0.3W | PXM1027 |
| | 6 | Flexible Cable (26P) | VDA1865 |
| | 7 | Connector Assy 2P | VKP2253 |
| | 8 | Float Rubber | VEB1327 |
| | 9 | Belt | VEB1330 |
| | 10 | Stabilizer | VNE2253 |
| | 11 | Loading Base | VNL1917 |
| | 12 | Float Base DVD | VNL1918 |
| | 13 | Drive Cam | VNL1919 |
| | 14 | Gear Pulley | VNL1921 |
| | 15 | Loading Gear | VNL1922 |
| | 16 | Drive Gear | VNL1923 |
| | 17 | SW Lever | VNL1925 |
| | 18 | Clamper Plate | VNE2251 |
| | 19 | Bridge | VNE2252 |
| | 20 | Clamper | VNL1924 |
| | 21 | Screw | JGZ17P028FMC |
| | 22 | Screw | Z39-019 |
| | 23 | Tray | VNL1920 |

A

B

C

D

E

F

Application of Lubricant

A

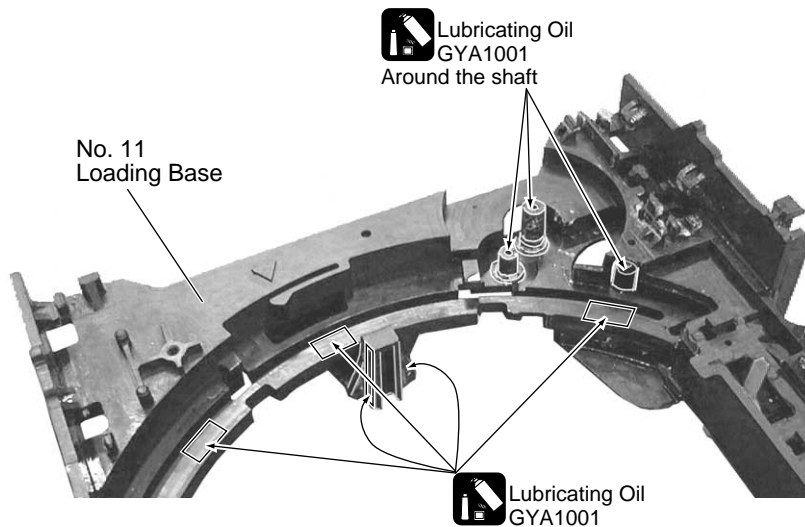

B

C

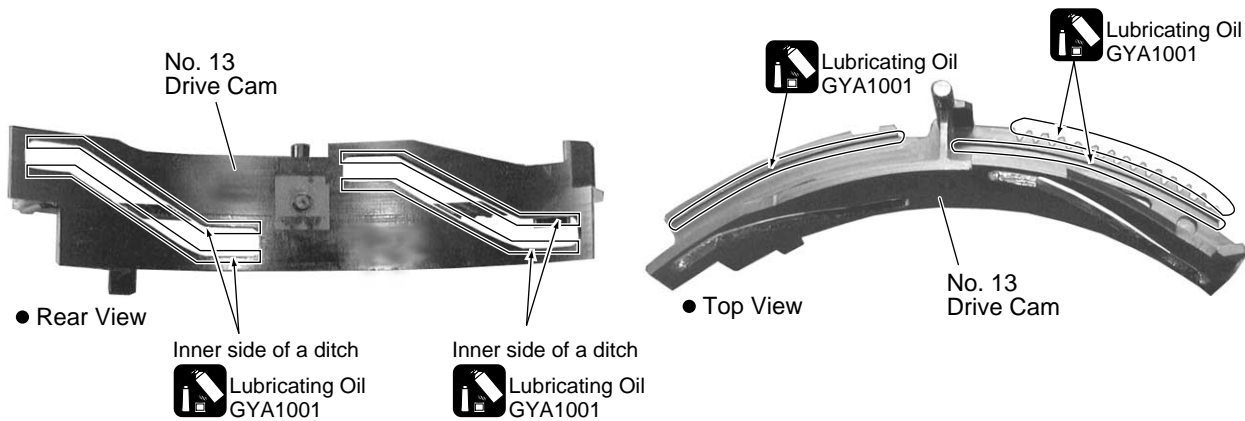

D

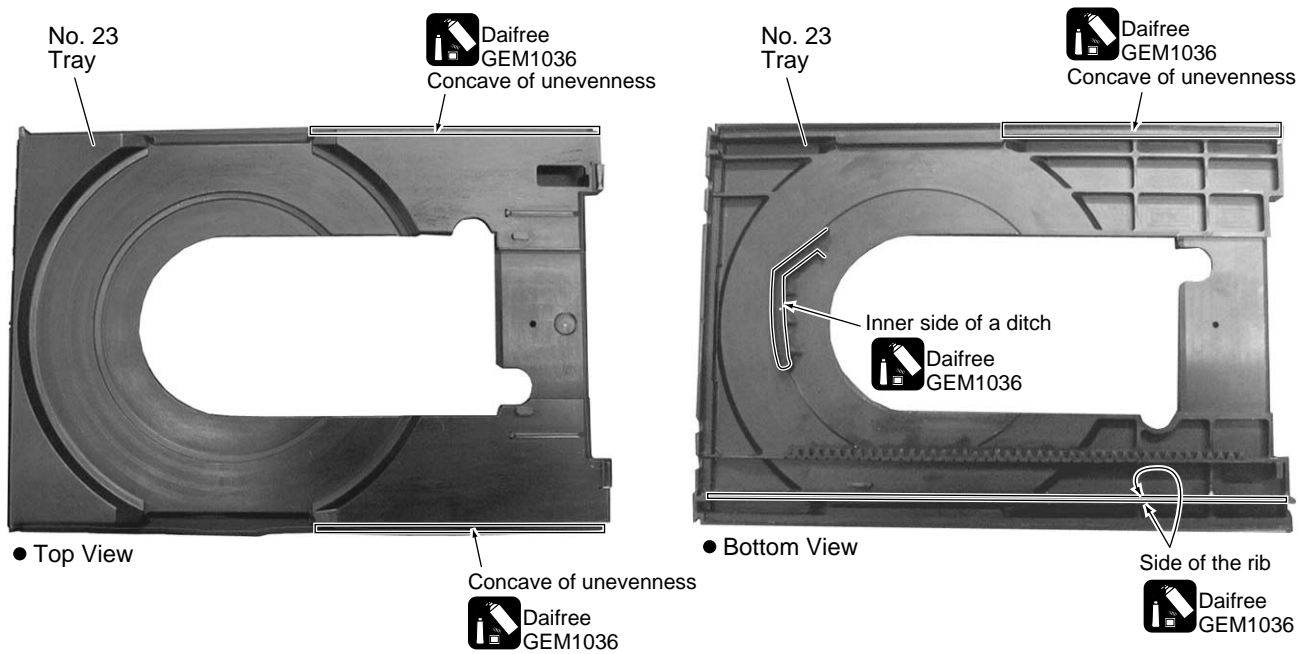

F

A

B

C

D

E

F

2.4 TRAVERSE MECHANISM ASSY-S

A
B
C
D
E
F

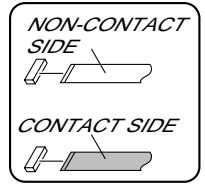
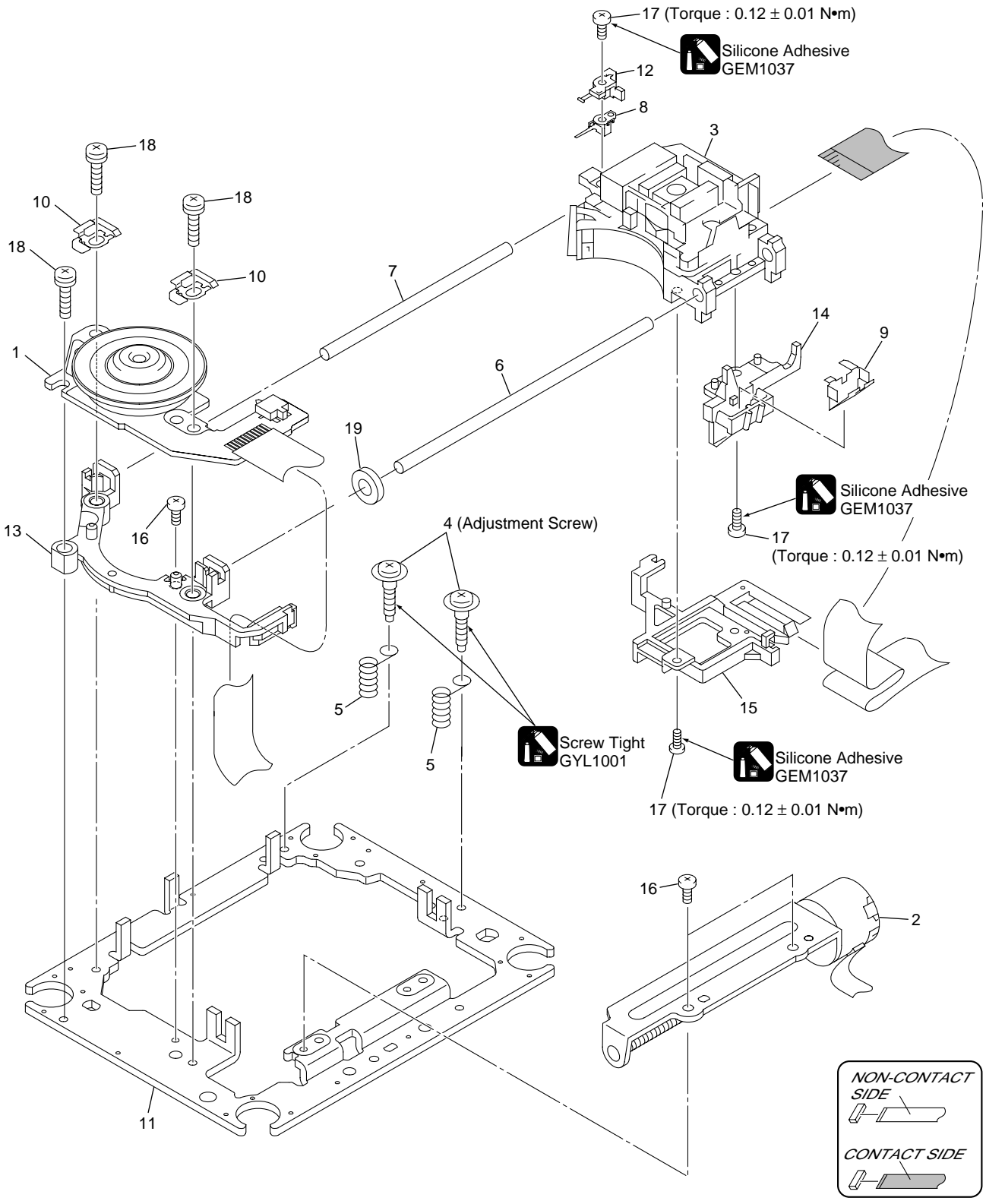

● TRAVERSE MECHANISM ASSY-S PARTS LIST

| Mark | No. | Description | Part No. |
|------|-----|-------------------|-------------------------|
| | 1 | Spindle Motor | VXM1088 (or VXM1089) |
| | 2 | Stepping Motor | VXM1090 (or VXM1091) |
| | 3 | Pickup Assy-S | OXX8003 |
| | 4 | Skew Screw | VBA1080 |
| | 5 | Skew Spring | VBH1335 |
| | 6 | Guide Bar | VLL1514 |
| | 7 | Sub Guide Bar | VLL1515 |
| | 8 | Hold Spring | VNC1017 |
| | 9 | Joint Spring | VNC1019 |
| | 10 | Support Spring | VNC1020 |
| NSP | 11 | Mechanism Chassis | VNE2248 |
| | 12 | Slider | VNL1811 |
| | 13 | Spacer | VNL1913 |
| | 14 | Joint | VNL1914 |
| | 15 | FFC Holder | VNL1915 |
| | 16 | Screw | BBZ20P050FZK |
| | 17 | Tapping Screw | OBA8009 |
| | 18 | Screw | PMA26P100FMC |
| | 19 | Damper Sheet | VEB1335 |

A

B

C

D

E

F

3. BLOCK DIAGRAM AND SCHEMATIC DIAGRAM

3.1 BLOCK DIAGRAM

3.1.1 SIGNAL ROUTE

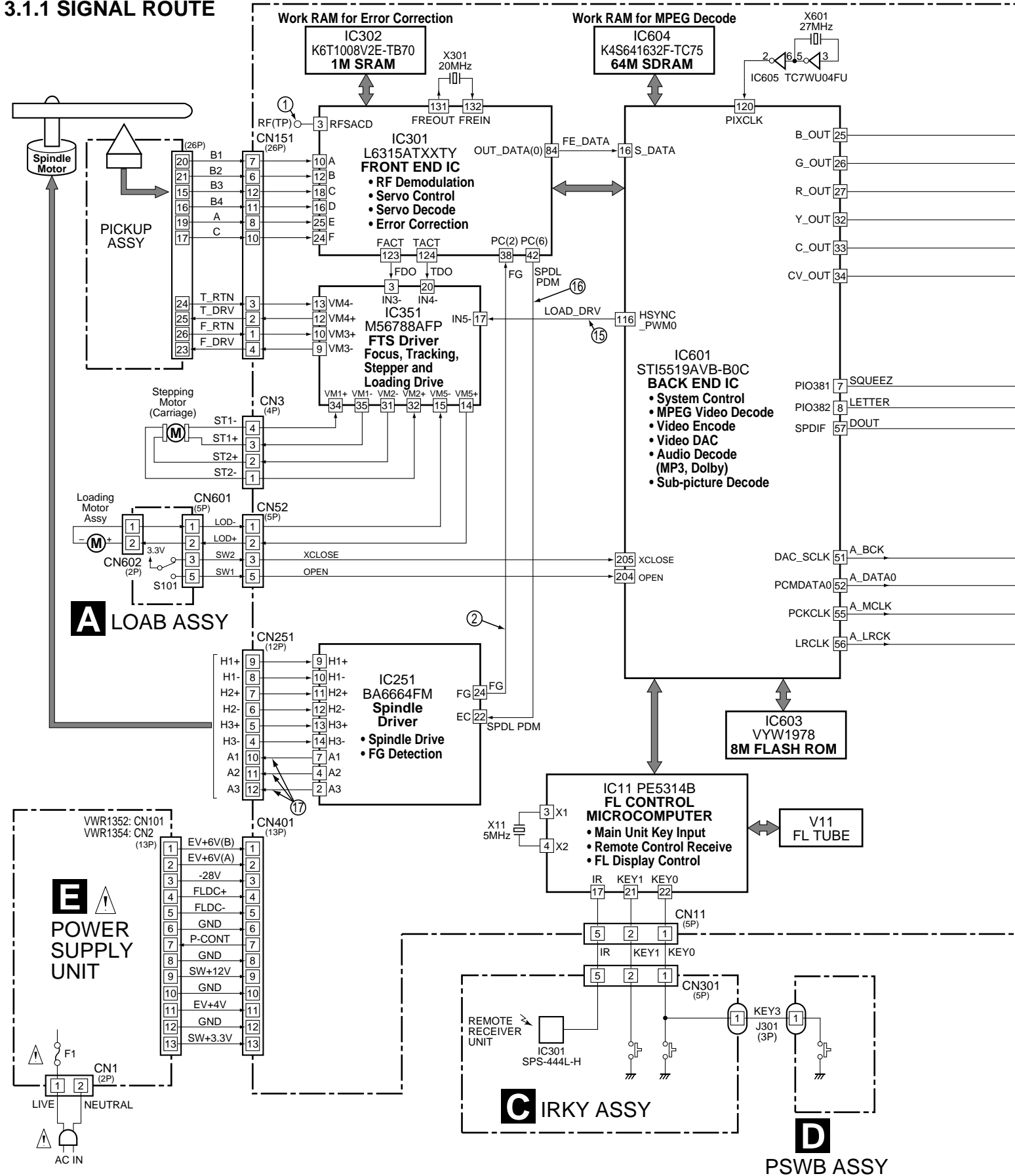

B FJMB ASSY

①-⑰: Refer to "3.1.3 WAVEFORMS".

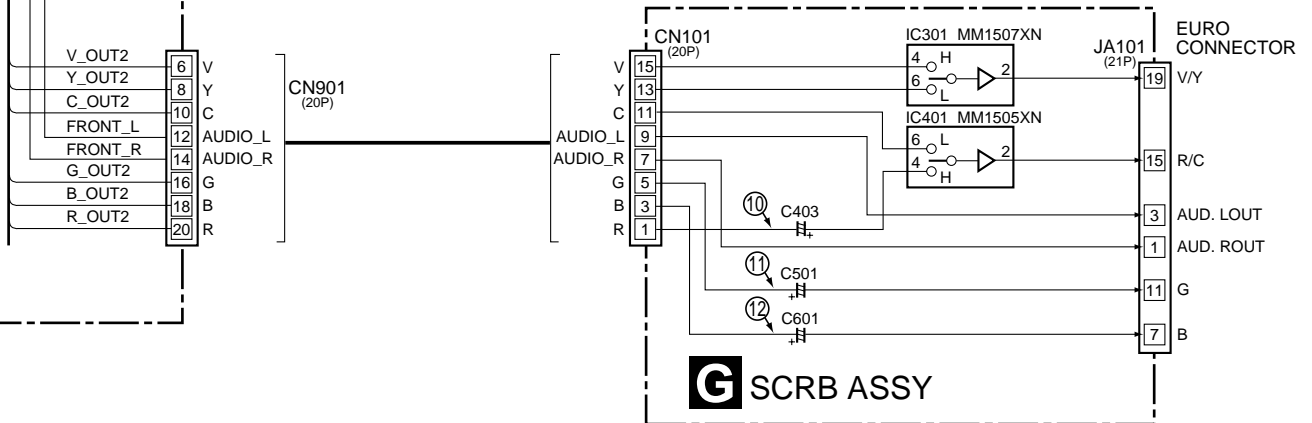
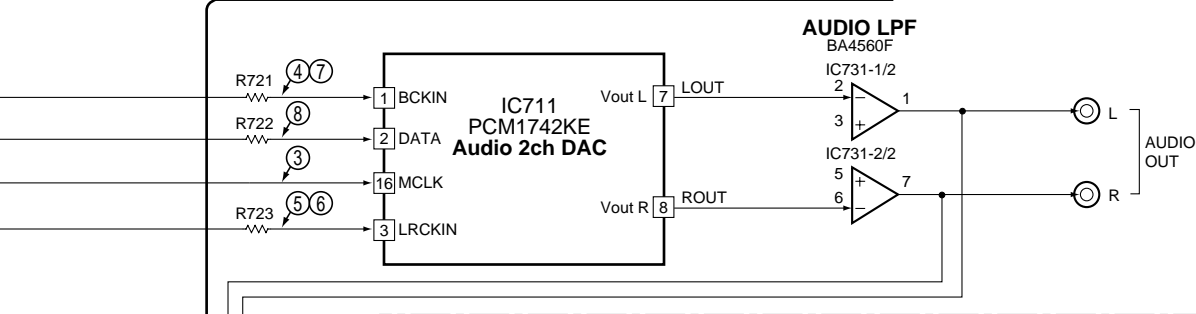
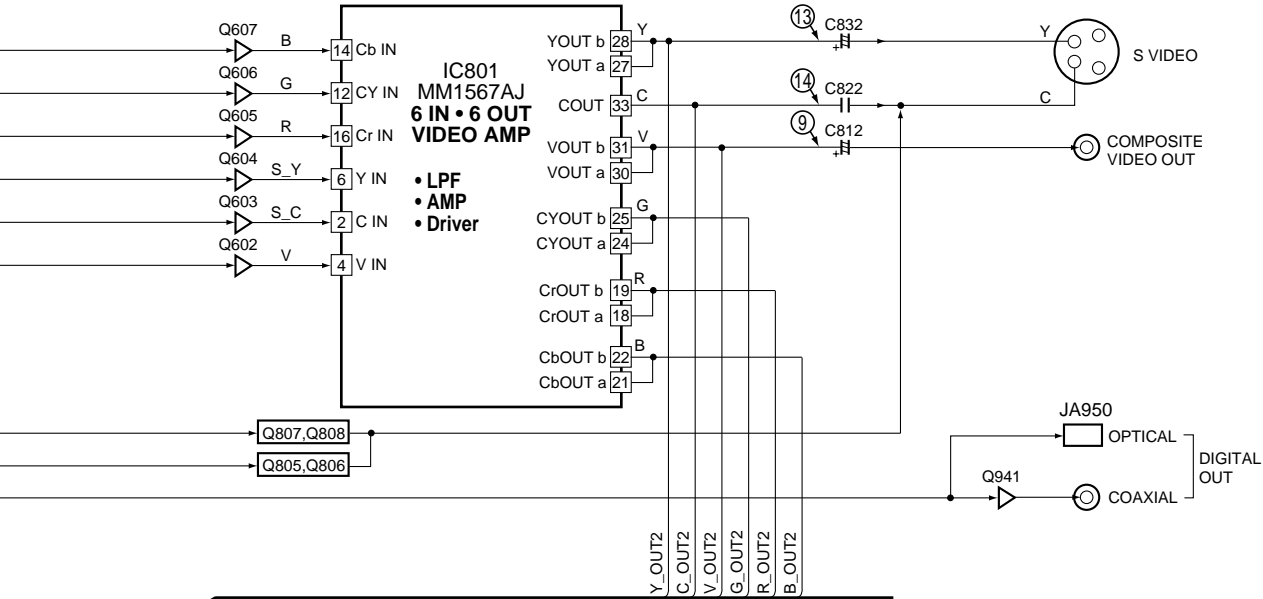

3.1.2 POWER SUPPLY BLOCK

A

B

C

D

E

F

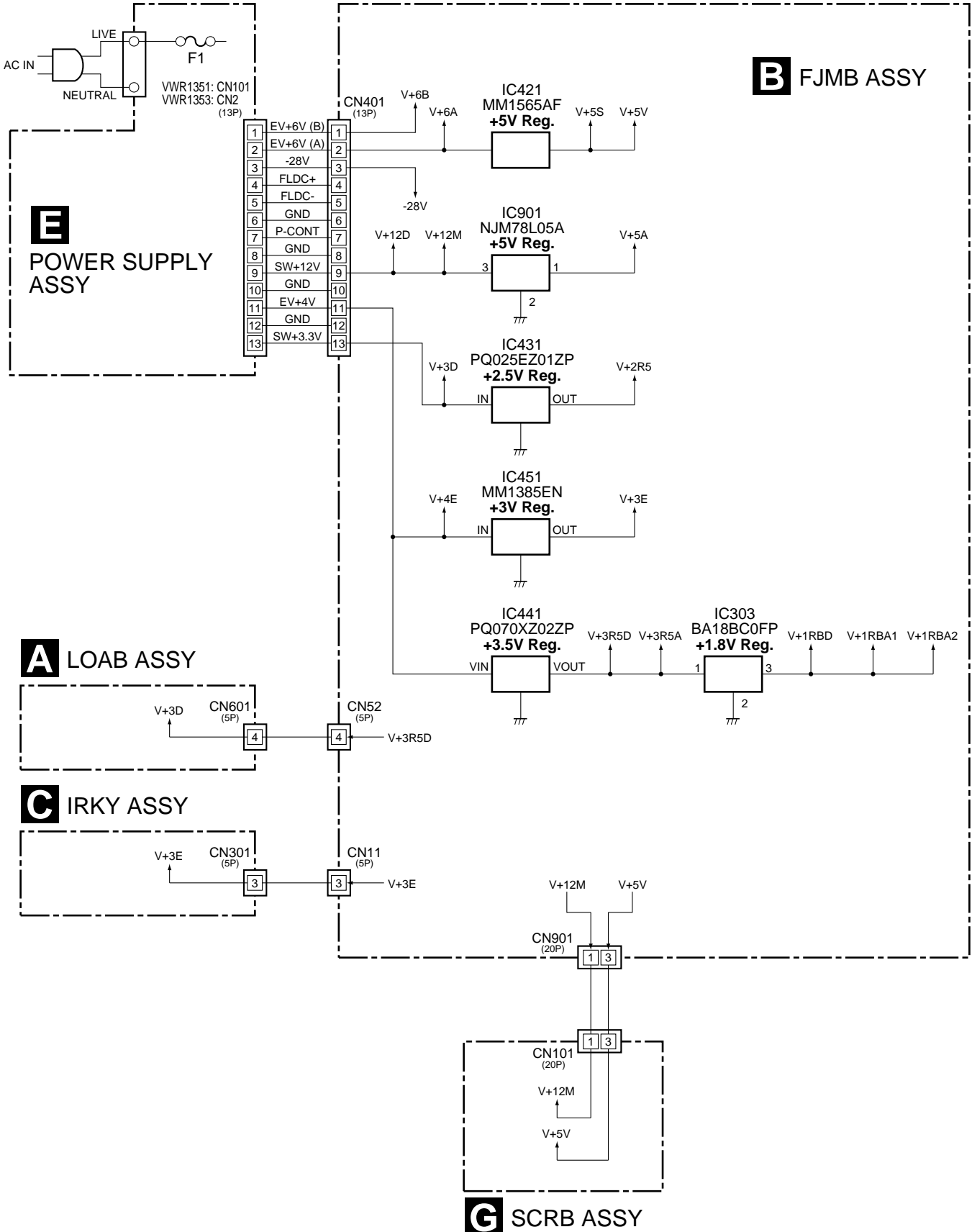

3.1.3 WAVEFORMS

Note : The encircled numbers denote measuring point in the schematic diagram.

Measurement condition : No. 1 to 2 and 9 to 14 : reference A1 (DVD), T2-chp 19, Color-bar
No. 3 to 8 : reference A1 (DVD), T2-chp 1

B FJMB ASSY

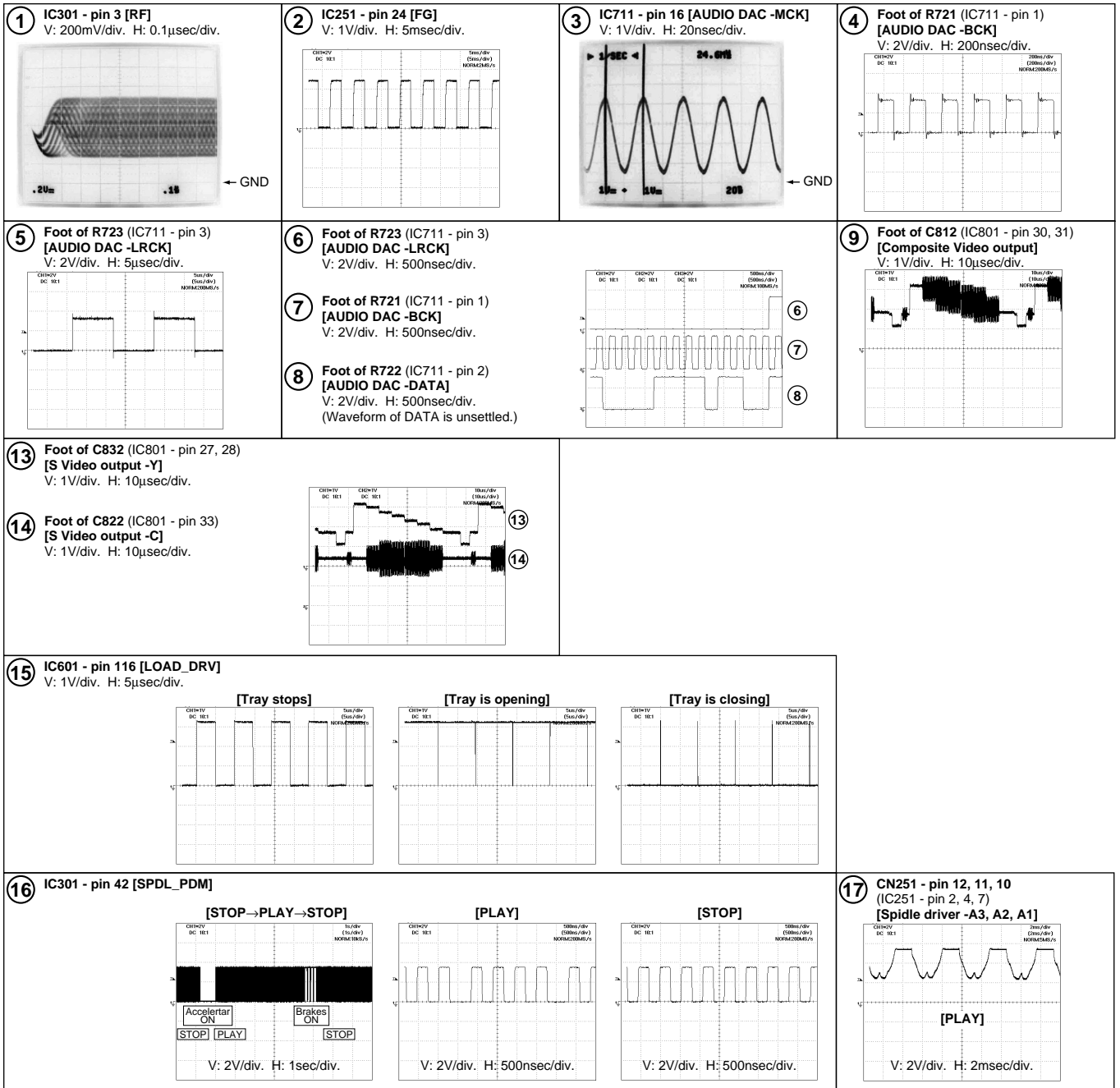

G SCRB ASSY

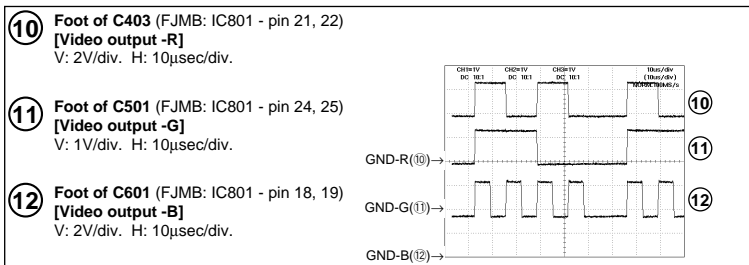

3.2 LOAB ASSY and OVERALL WIRING DIAGRAM

A

B

C

D

E

F

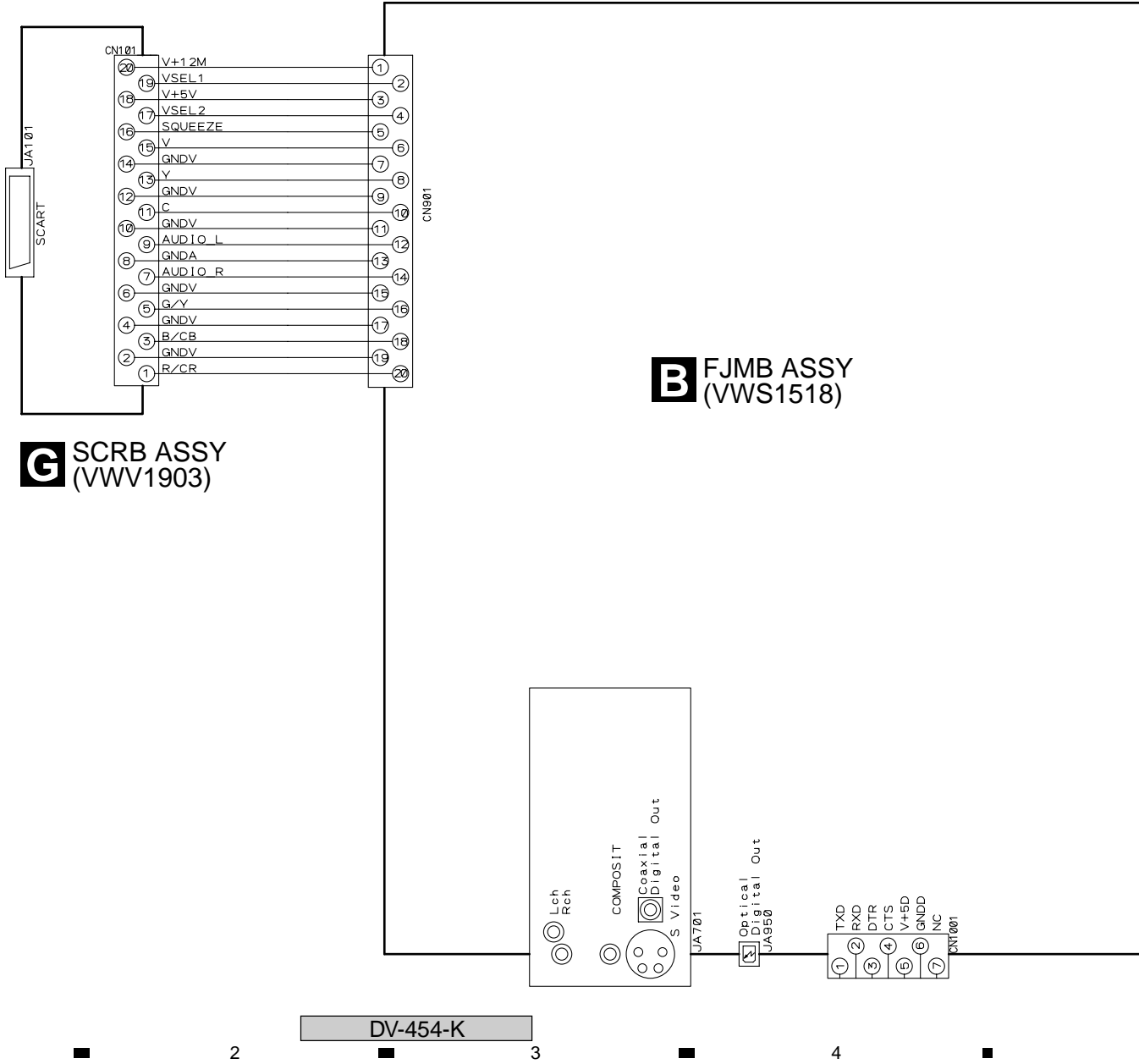

Note : When ordering service parts, be sure to refer to "EXPLODED VIEWS and PARTS LIST" or "PCB PARTS LIST"

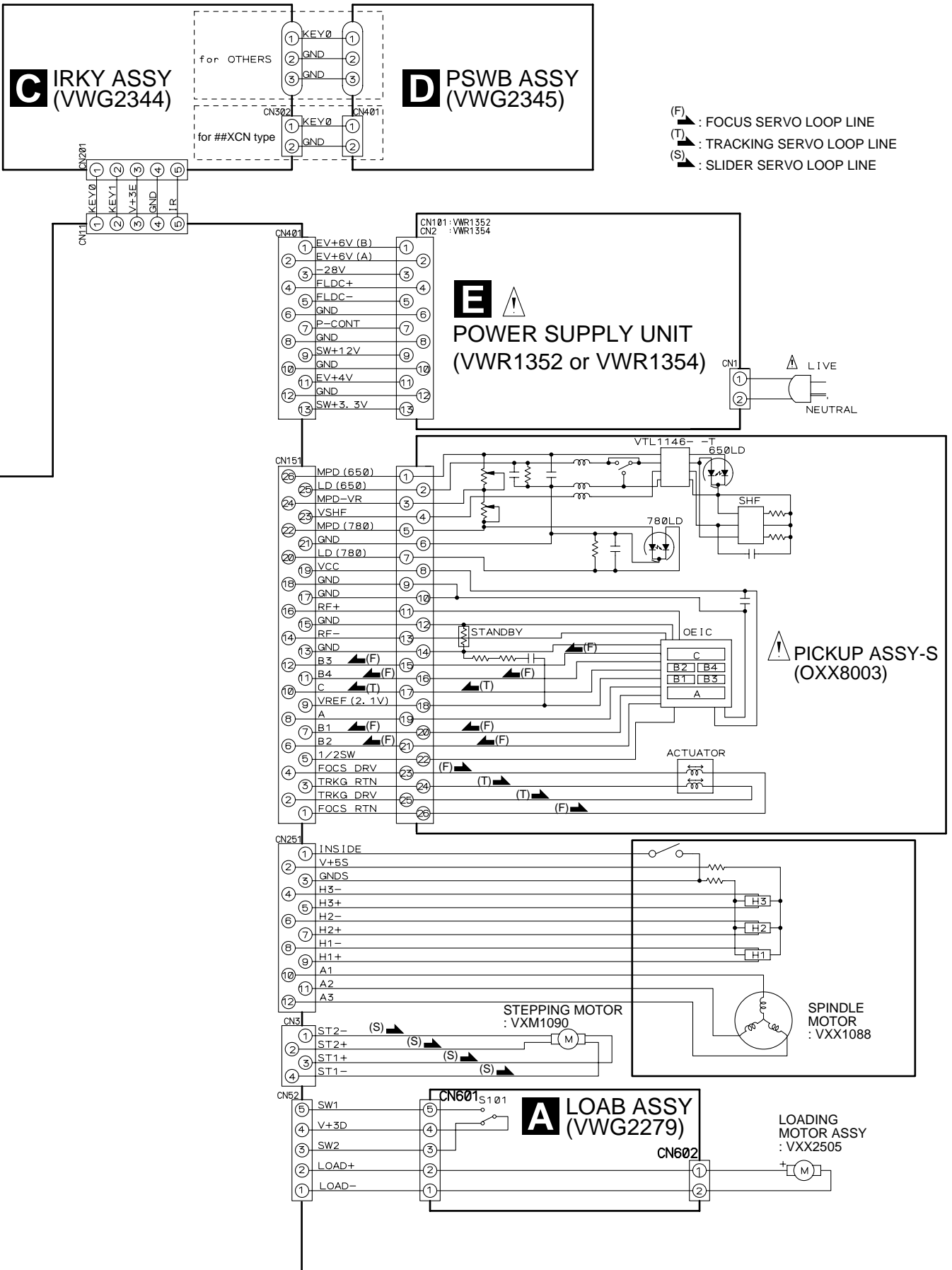

3.3 FJMB ASSY 1/5 [FRONT END BLOCK]

B 1/5 FJMB ASSY (VWS1518)

Bus No. 1 to Schema 2/5 B 2/5

A CN601

for LOAB ASSY

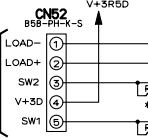

for PU ASSY

CN151

VKN1798-TF8

PICKUP ASSY

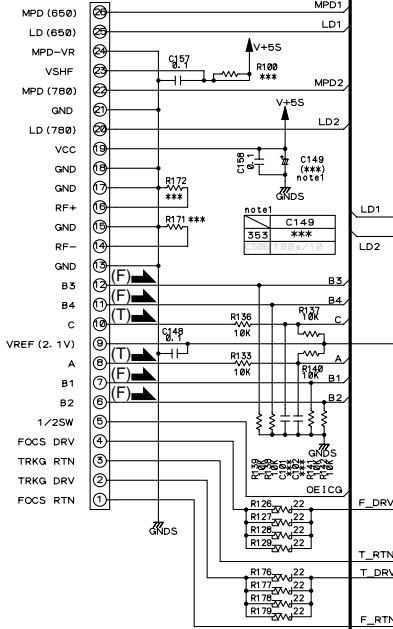

STEPPING MOTOR

SPINDLE MOTOR

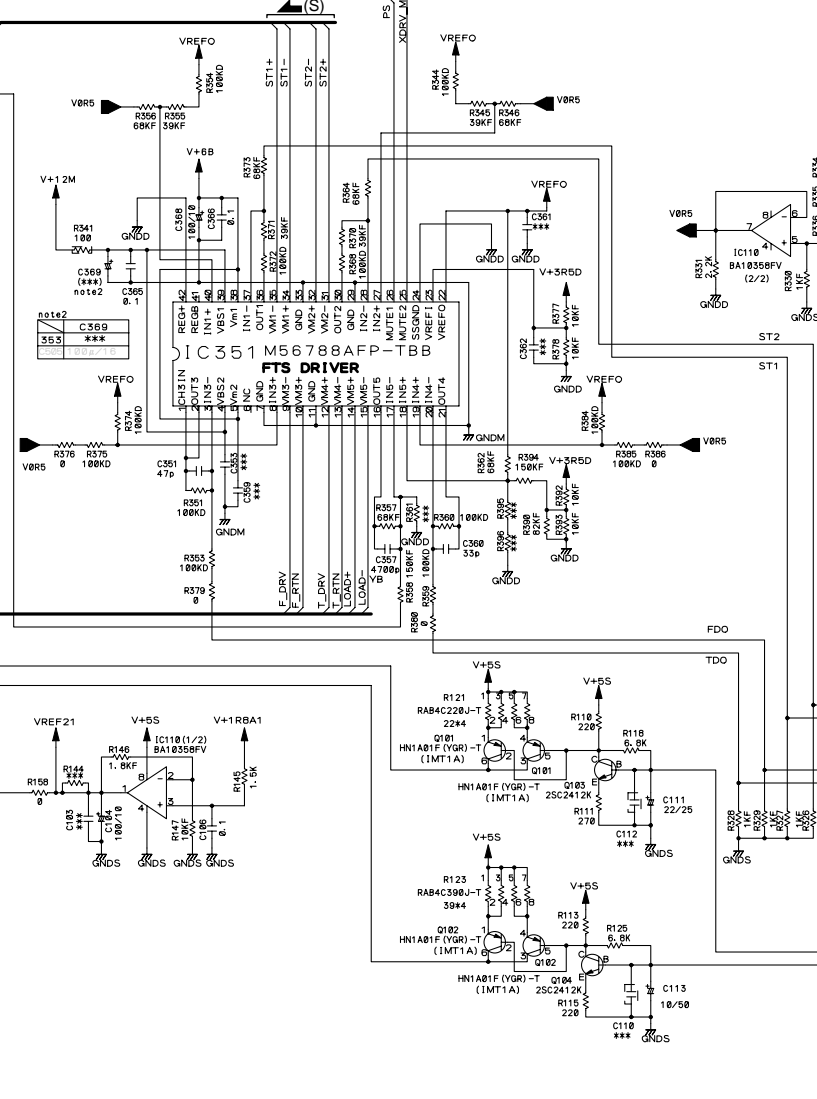
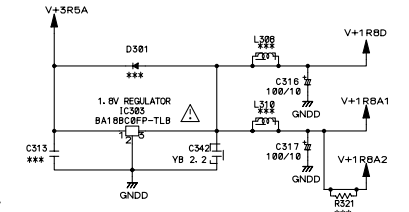
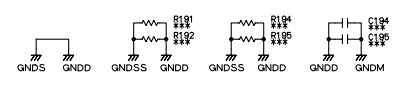
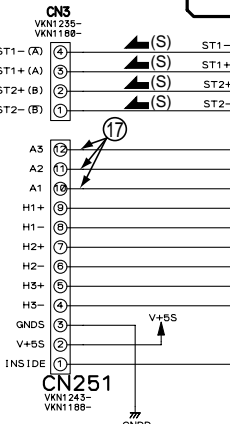

B 1/5

Bus No. 1 to Schema 2/5 B/25

①, ②, ⑬, ⑰: Refer to "3.1.3 WAVEFORMS".

- (F) : FOCUS SERVO LOOP LINE
- (T) : TRACKING SERVO LOOP LINE
- (S) : SLIDER SERVO LOOP LINE

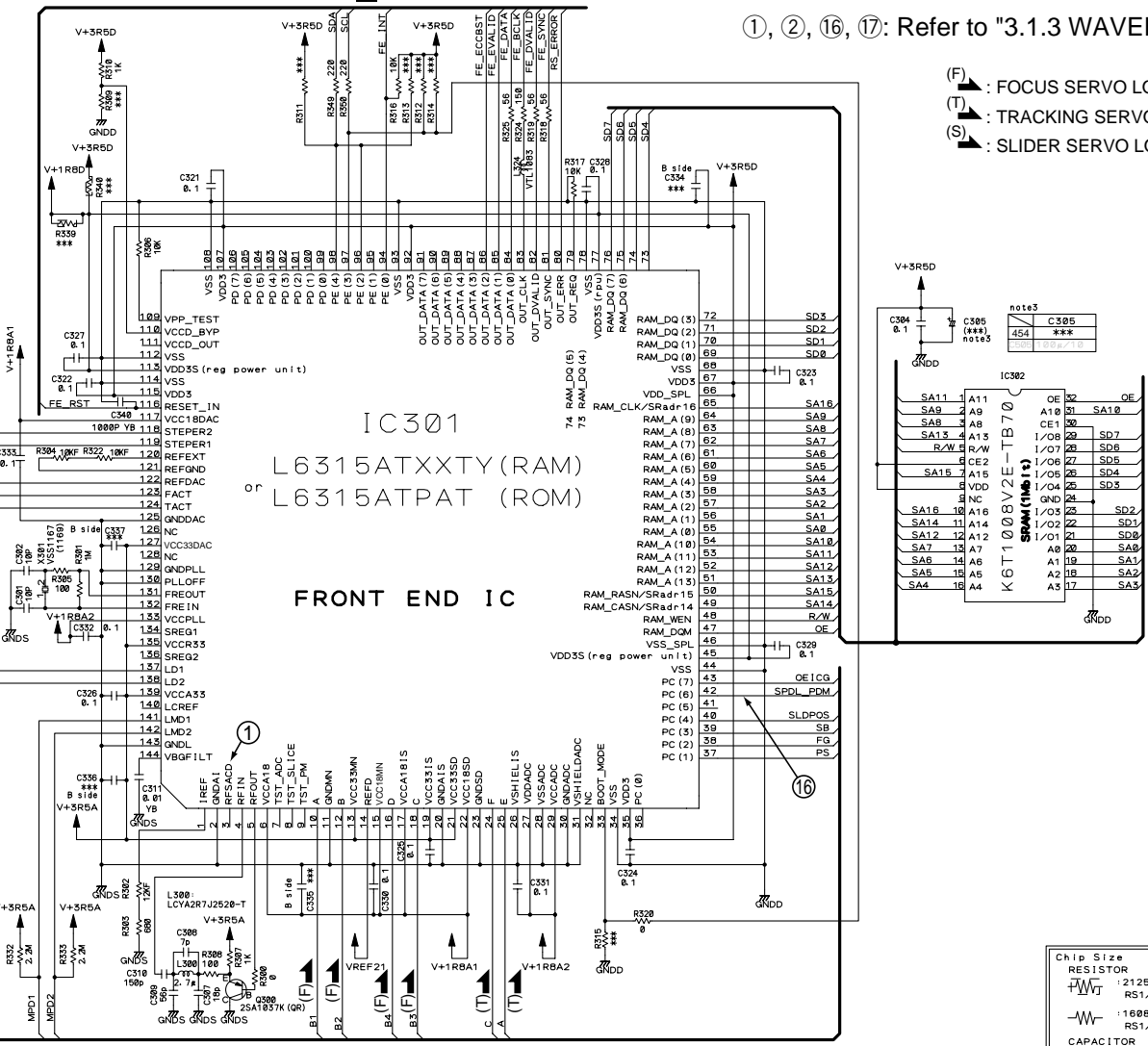

Chip Size

RESISTOR

2125Size
RS1/16S~

1606Size
RS1/16S~

CAPACITOR

2125Size
CK50K~

1606Size
CCSR~
CK5R~

***: parts not mounted

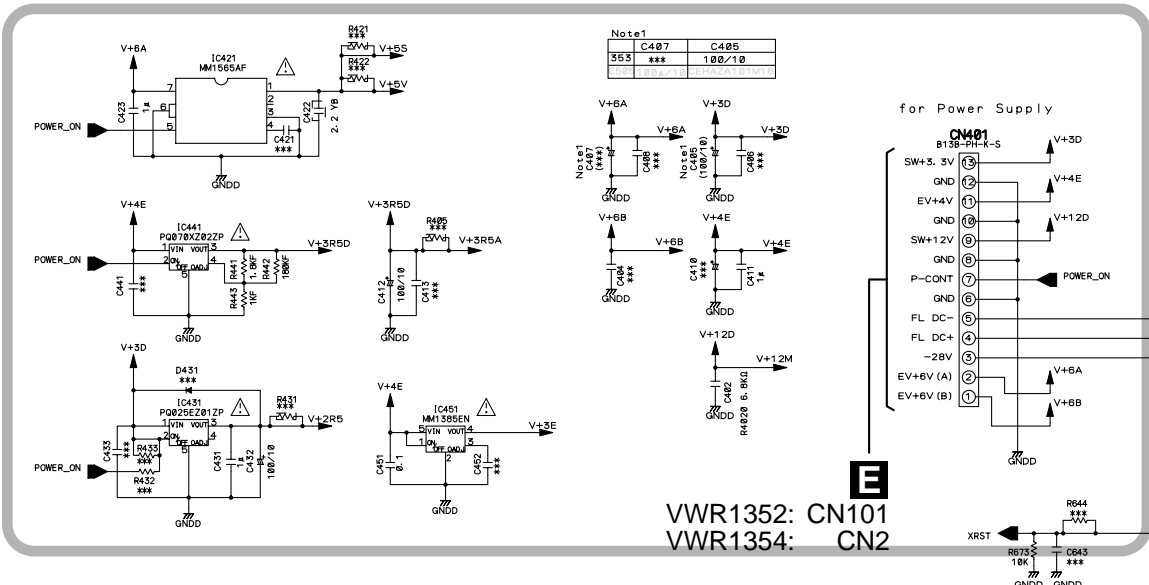

Note1

| | |
|------|--------|
| C407 | C485 |
| 553 | 100/10 |

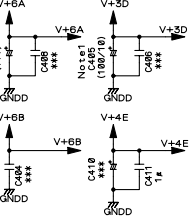

VWR1352: CN101
VWR1354: CN2

Bus No. 2 to Schema 2/5, 5/5 B2/5 B5/5

Ⓞ : The power supply is shown with the marked box.

Note9

| | |
|---------------------|--------------|
| WVS1515 ~WVS1522 | R573 R595 |
| *** | *** |

Note4

| | |
|------|----------------|
| L699 | C698 |
| 454 | LCYA2R2J2528-T |

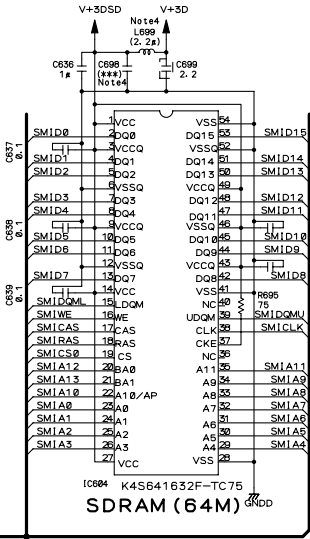

SMI BUS

Note3

| | |
|---------|------|
| WVS1515 | R688 |
| WVS1518 | 33 |
| WVS1519 | |
| WVS1520 | |
| WVS1521 | |
| WVS1522 | 27 |

VIDEO OUT

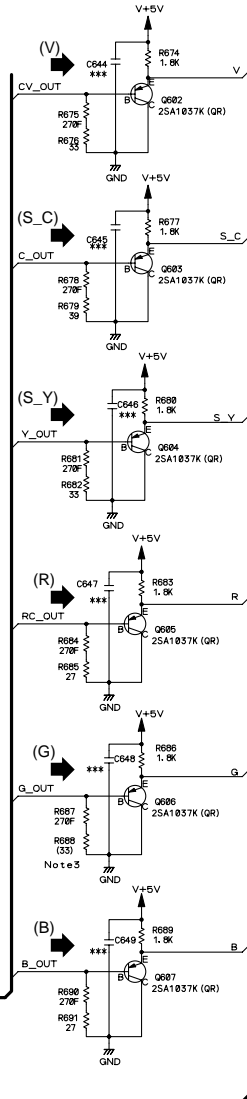

Bus No. 3 to Schema 3/5, 4/5 (to JACK) B3/5 B4/5

⑮: Refer to "3.1.3 WAVEFORMS".

- (V) : V SIGNAL ROUTE
- (S_C) : S-VIDEO OUT C SIGNAL ROUTE
- (S_Y) : S-VIDEO OUT Y SIGNAL ROUTE
- (R) : R SIGNAL ROUTE
- (G) : G SIGNAL ROUTE
- (B) : B SIGNAL ROUTE
- Ⓜ : AUDIO SIGNAL ROUTE
- Ⓜ : AUDIO(DIGITAL) SIGNAL ROUTE

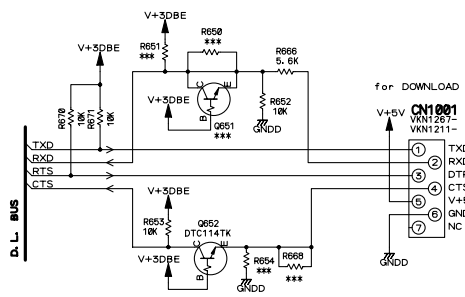

***: parts not mounted

3.5 FJMB ASSY 3/5 [AUDIO BLOCK]

B 3/5 FJMB ASSY (VWS1518)

Bus No. 3 to Schema 2/5 B 2/5

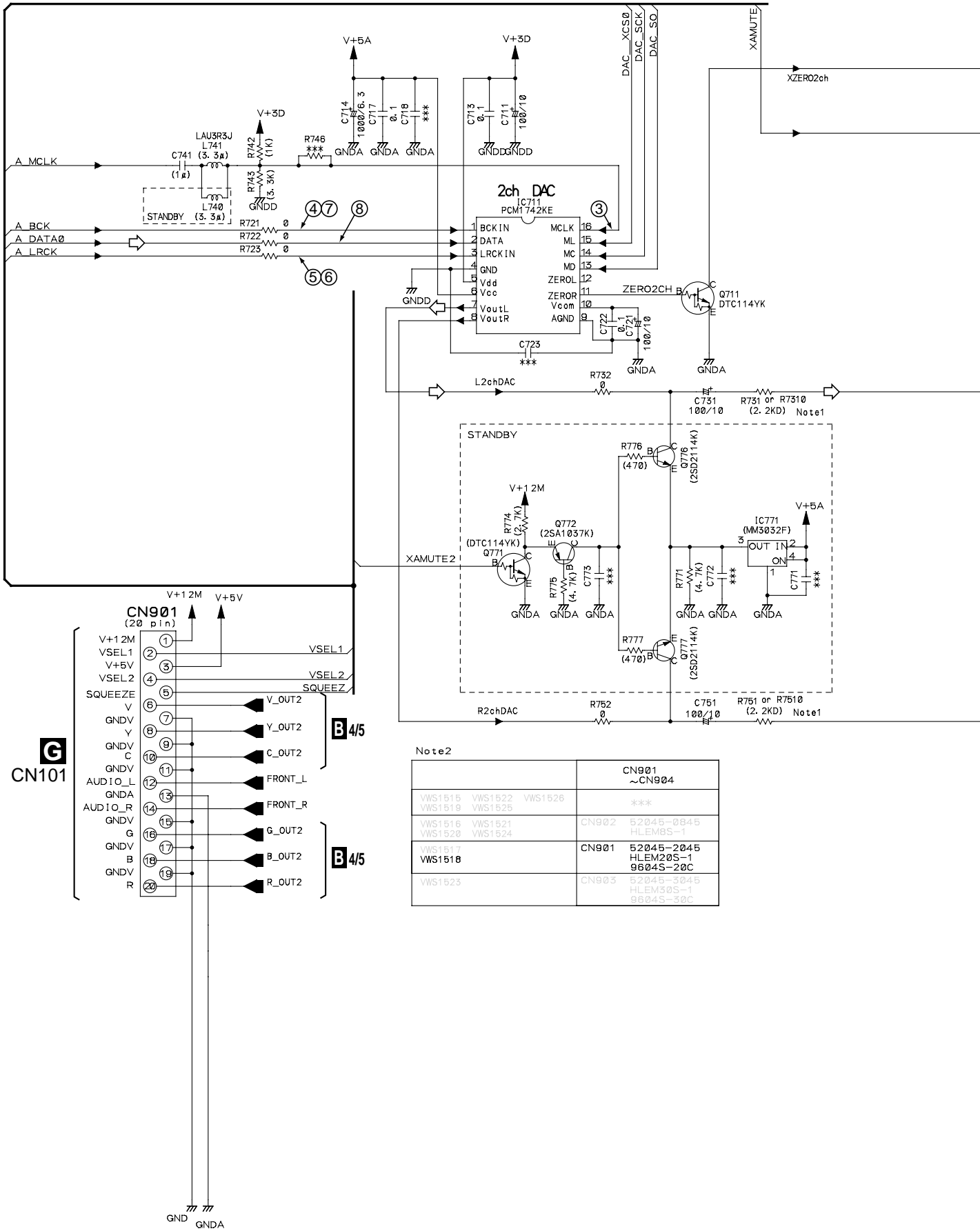

G
CN101

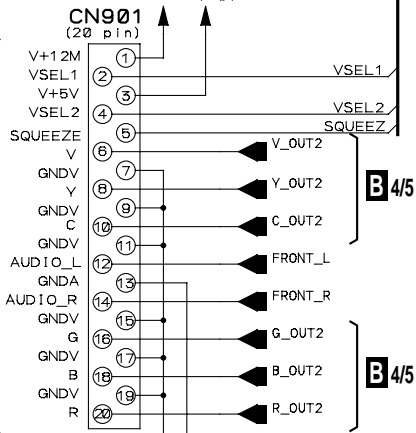

Note2

| | | | CN901 ~ CN904 | |
|---------|---------|---------|---------------|--------------------------------------|
| VWS1515 | VWS1522 | VWS1526 | *** | |
| VWS1519 | VWS1525 | | *** | |
| VWS1518 | VWS1521 | VWS1524 | CN902 | 52045-0845 HLEM8S-1 |
| VWS1517 | VWS1518 | | CN901 | 52045-2045 HLEM205-1 96045-20C |
| VWS1523 | | | CN903 | 52045-3045 HLEM305-1 96045-30C |

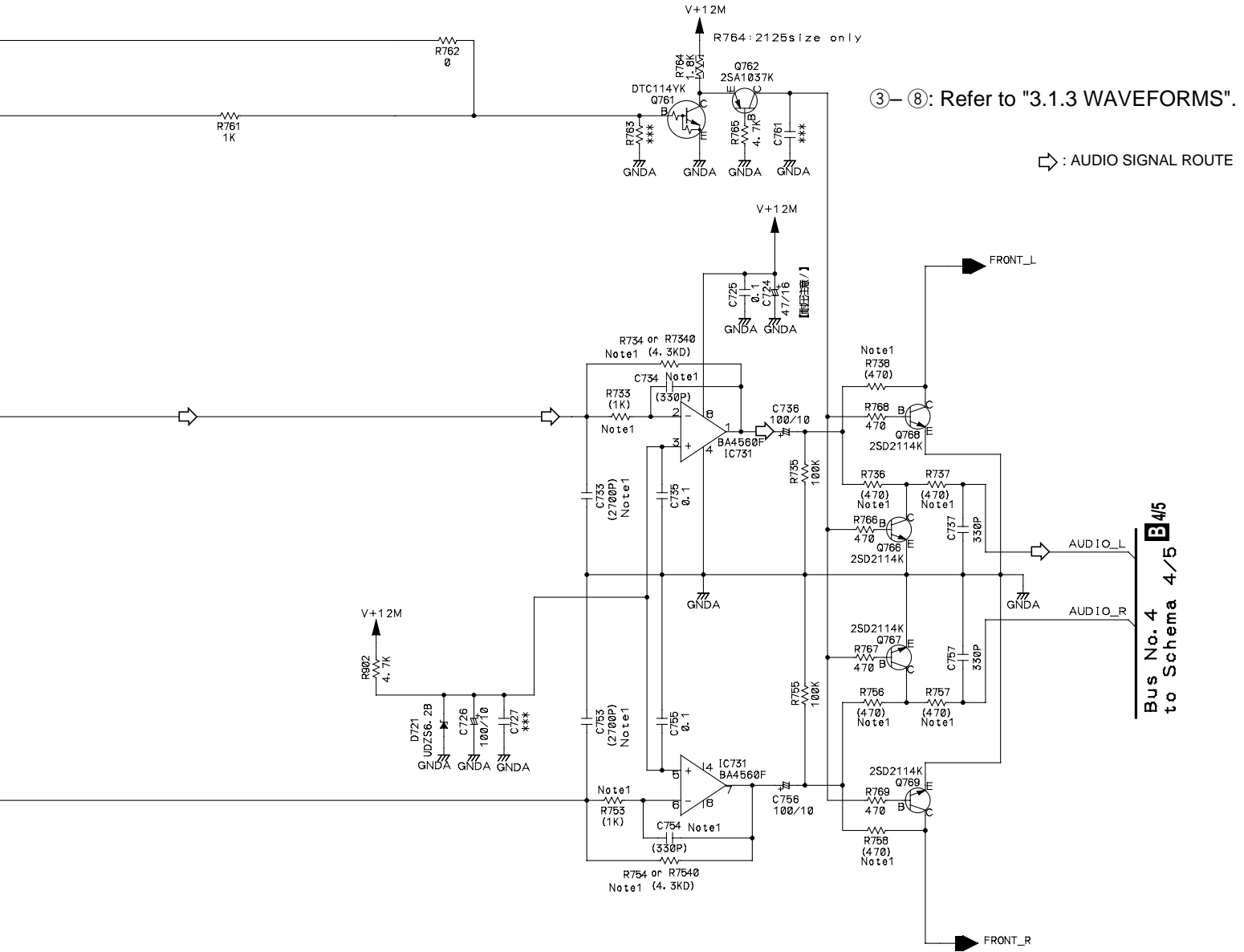

③-⑧: Refer to "3.1.3 WAVEFORMS".

⇒ : AUDIO SIGNAL ROUTE

Bus No. 4
to Schema 4/5

Note1

| | R731 R751 | R733 R753 | R734 R754 | C733 C753 | C734 C754 | R736 R737 R756 R757 | R738 R758 | R739 R759 |
|------------------------------------|--------------|--------------|--------------|--------------|------------------------------|------------------------------|--------------|--------------|
| VWS1515 VWS1521 VWS1516 VWS1522 | 2. 2K | 1K | 4. 3K | 2700P YB | VCH1226 VCH1227 (330P) | 470 | *** | *** |
| VWS1517 VWS1518 | | | | | | | 470 | *** |
| VWS1526 | | | | | | | 470 | 470 |
| VWS1519 VWS1524 VWS1520 VWS1525 | 16K | 22K | 27K | 330P CH | 33P | 220 | *** | *** |
| VWS1523 | | | | | | | 220 | 220 |

R731 , R751 , R734 , R754 : RN1/16SE****D
R7310, R7510, R7340, R7540: RD1/4PU***J

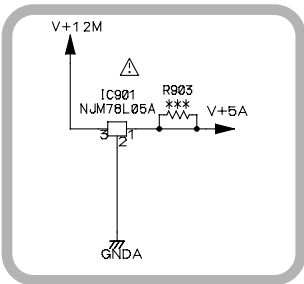

○ : The power supply is shown with the marked box.

***:parts not mounted

3.6 FJMB ASSY 4/5 [VIDEO BLOCK]

B 4/5 FJMB ASSY (VWS1518)

A

B

C

D

E

F

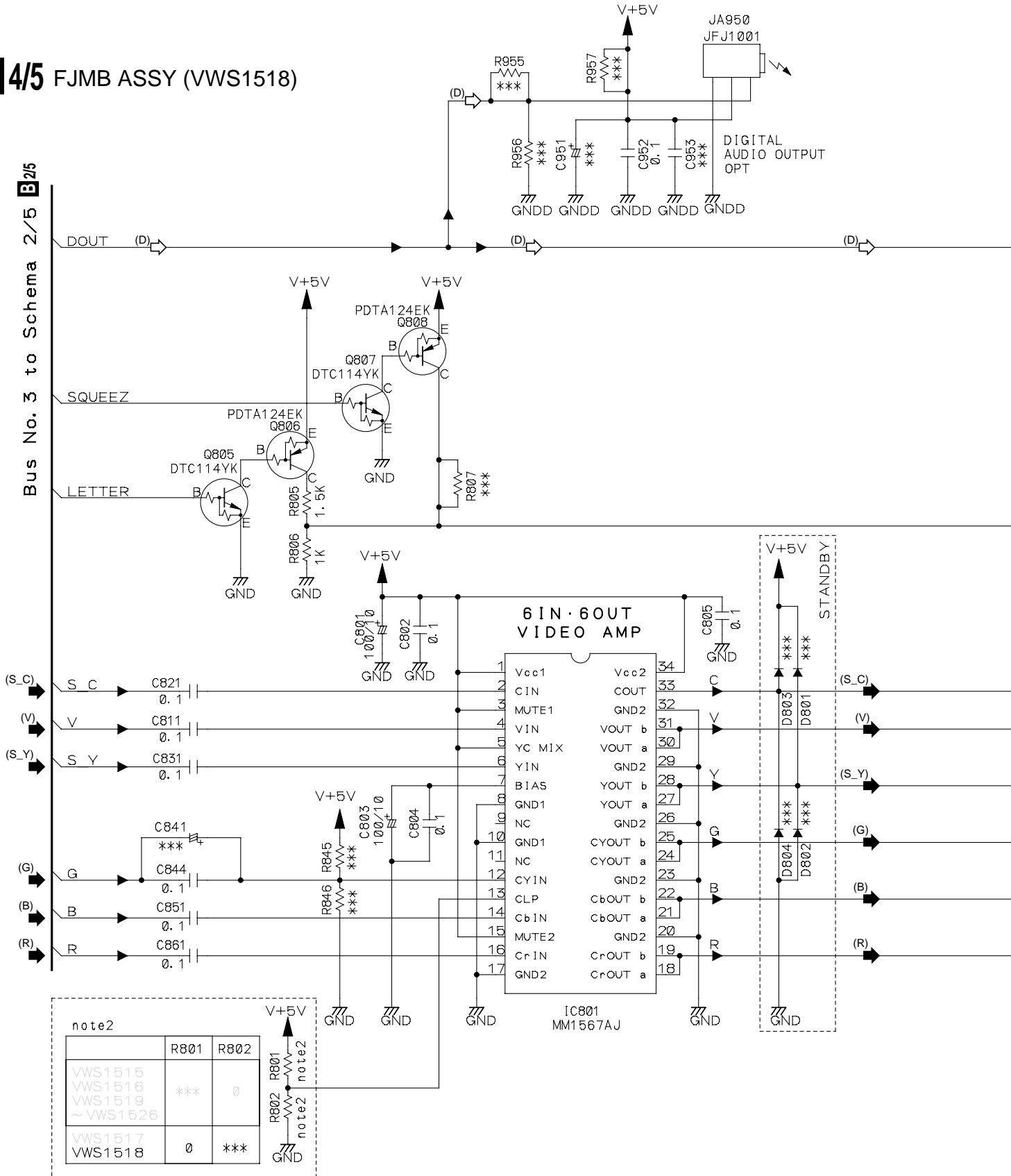

***: parts not mounted

B 4/5

| | |
|--------------------------------------------|--------------------|
| note1 | |
| | JA701 |
| VWS1515 VWS1516 VWS1519 ~ VWS1526 | VKB1179- (8pin) |
| VWS1517 VWS1518 | VKB1180- (5pin) |

- (V) : V SIGNAL ROUTE
- (S_C) : S-VIDEO OUT C SIGNAL ROUTE
- (S_Y) : S-VIDEO OUT Y SIGNAL ROUTE
- (R) : R SIGNAL ROUTE
- (G) : G SIGNAL ROUTE
- (B) : B SIGNAL ROUTE
- (A) : AUDIO SIGNAL ROUTE
- (D) : AUDIO(DIGITAL) SIGNAL ROUTE

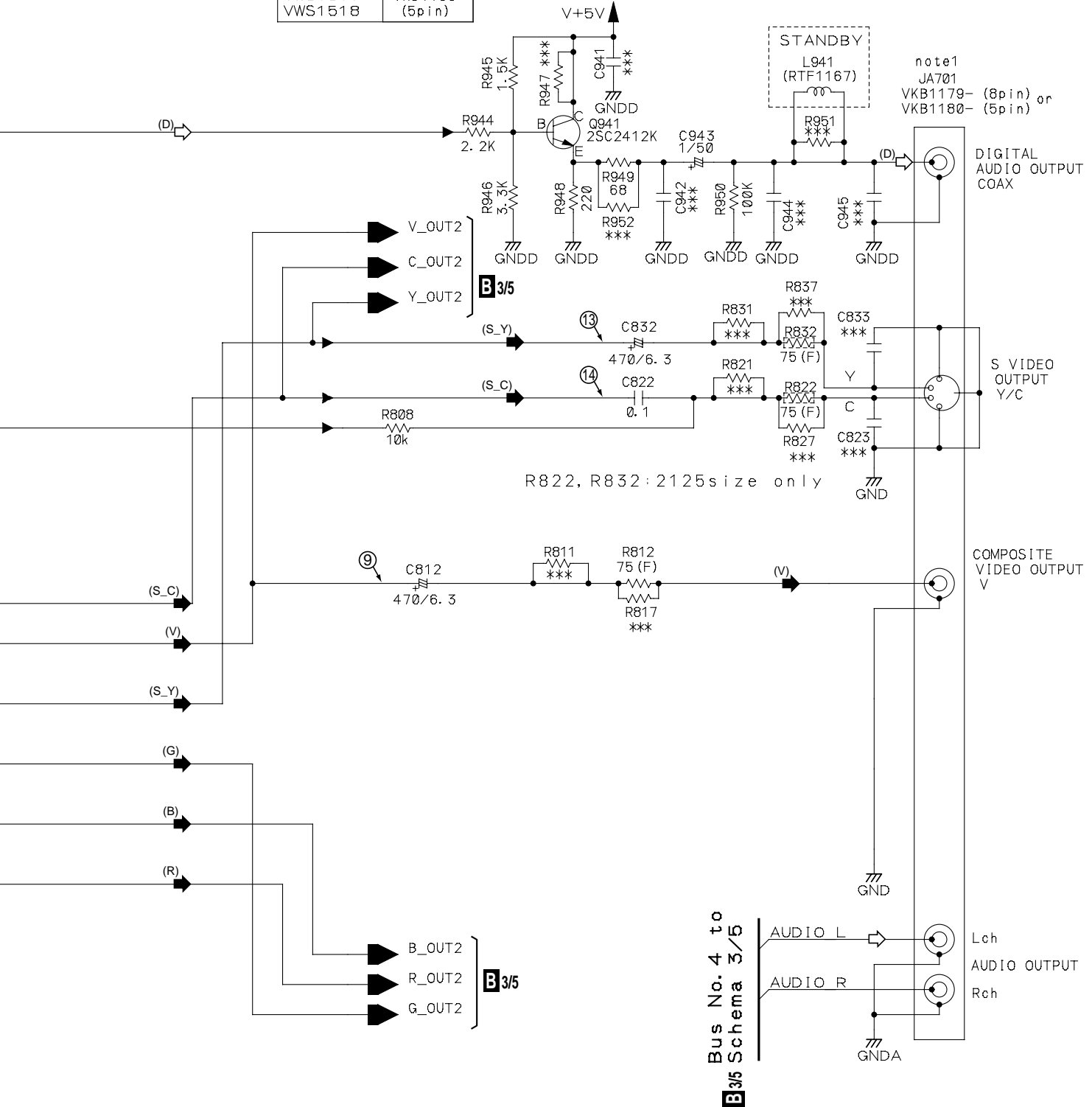

⑨, ⑬, ⑭: Refer to "3.1.3 WAVEFORMS".

3.7 FJMB ASSY 5/5 [FL CONTROL BLOCK]

B 5/5 FJMB ASSY (VWS1518)

Note1

| Series | Model No. | A' ssy No. | Destination | | Model Select | | | | | |
|--------|--------------------|------------|-------------|------|--------------|-----|-----|-----|-----|-----|
| | | | R27 | R28 | R35 | R36 | R37 | R38 | R39 | R40 |
| 353 | DV-353-*/K*/25*/K* | VWS1515 | 33K | 5.6K | *** | 0 | *** | 0 | *** | 0 |
| | DV-353-*/J/J | VWS1516 | *** | 0 | *** | 0 | *** | 0 | *** | 0 |
| | DV-353-*/W*/ | VWS1517 | 3.3K | 4.7K | *** | 0 | *** | 0 | *** | 0 |
| | DV-454-*/W*/550/W* | VWS1518 | 3.3K | 4.7K | *** | 0 | *** | 0 | *** | 0 |
| | DV-2500/RAM | VWS1519 | 5.6K | 53K | *** | 0 | *** | 0 | *** | 0 |
| | DV-3500/RAM | VWS1520 | 5.6K | 33K | *** | 0 | *** | 0 | *** | 0 |
| | DV-5500KD/RAM | VWS1523 | 5.6K | 33K | *** | 0 | *** | 0 | 0 | *** |
| | DV-355/LB | VWS1521 | 1.5K | 1.2K | *** | 0 | *** | 0 | *** | 0 |
| | DV-555K/LB | VWS1524 | 1.5K | 1.2K | *** | 0 | *** | 0 | 0 | *** |

Note2 353 series only

| | R47 | R48 |
|---------|-----|-----|
| PIONEER | *** | 0 |
| OEM | 0 | *** |

Note3 353 series only

| | R44 | R74 |
|-------------------|-----|-----|
| VWS1515 ~ VWS1522 | 0 | *** |
| VWS1523 ~ VWS1525 | *** | 0 |

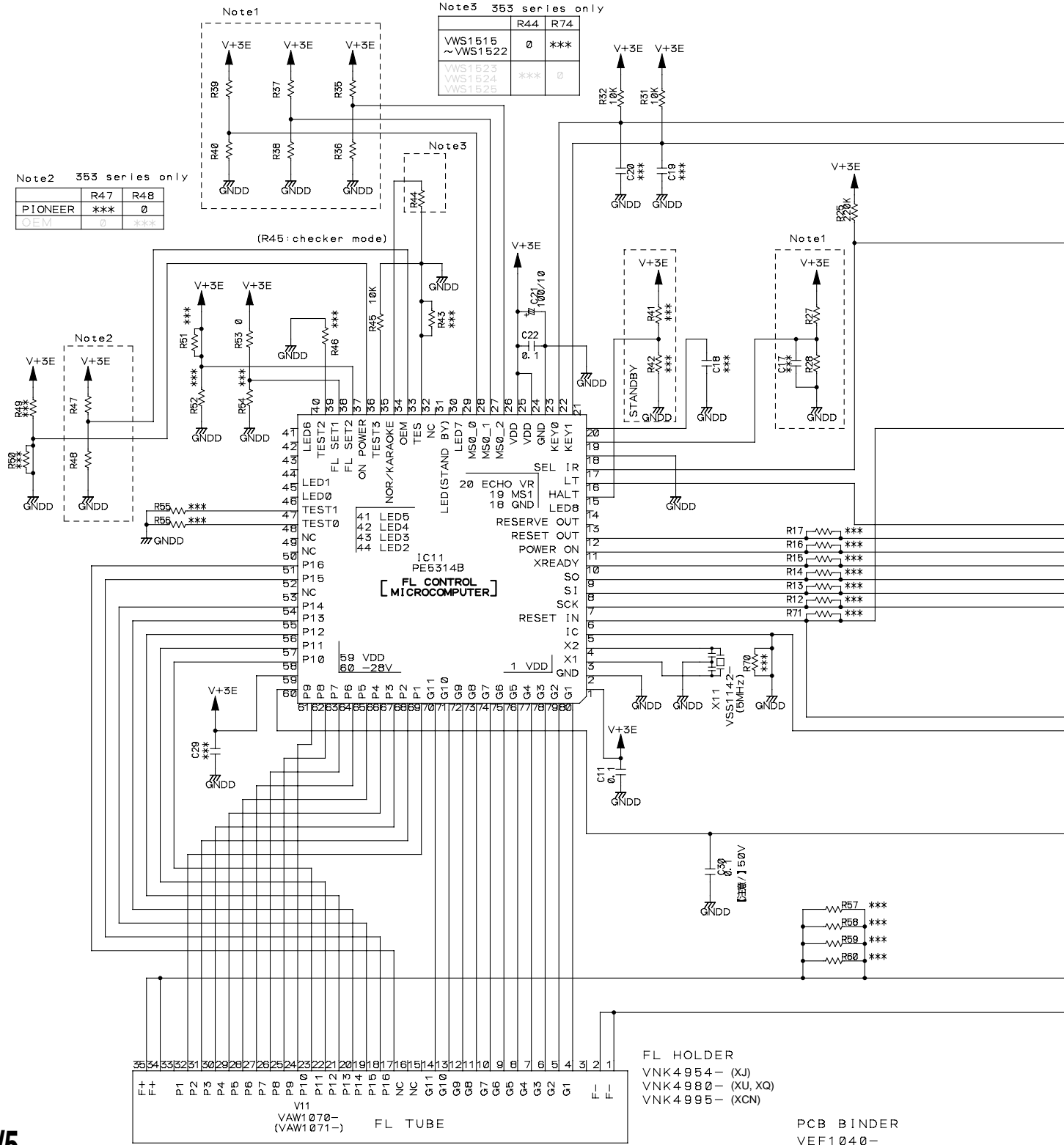

Note1

| Series | Model No. | A'ssy No. | Destination | | Model Select | | | | | |
|--------|---------------|-----------|-------------|------|--------------|-----|-----|-----|-----|-----|
| | | | R27 | R28 | R35 | R36 | R37 | R38 | R39 | R40 |
| 353 | DV-355*/R*/B* | VWS1522 | 6.8K | 2.7K | *** | 0 | *** | 0 | *** | 0 |
| | DV-555K/R*/B* | VWS1525 | 6.8K | 2.7K | *** | 0 | *** | 0 | 0 | *** |
| C505 | DV-C505 | VWS1526 | *** | *** | *** | *** | *** | *** | *** | *** |
| | | | | | | | | | | |

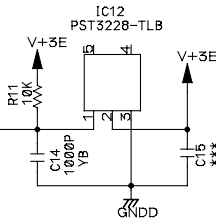
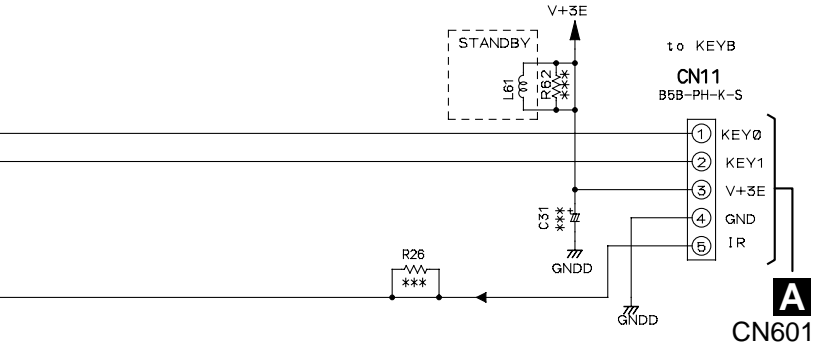

Note5

| | R20 | R22 | R23 | R24 |
|------|---------|---------|---------|---------|
| 454 | 1MΩ | *** | 10KΩ | 10KΩ |
| C505 | (C2000) | (C2200) | (C2300) | (C2400) |
| | 47pF | 47pF | 47pF | 47pF |

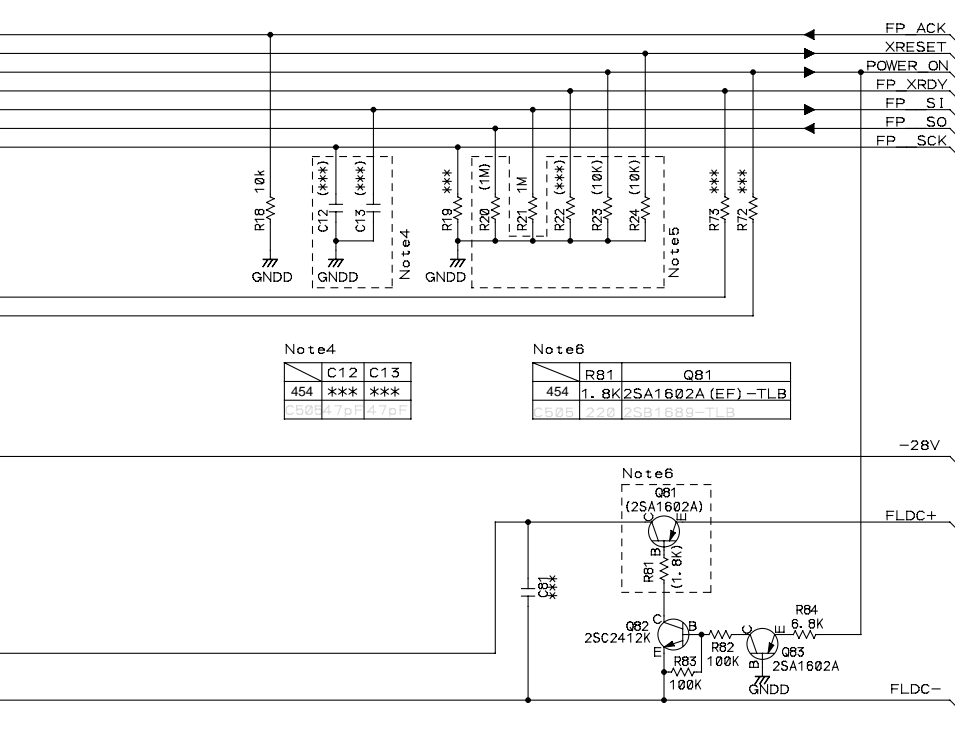

Note4

| | C12 | C13 |
|------|------|------|
| 454 | *** | *** |
| C505 | 47pF | 47pF |

Note6

| | R81 | Q81 |
|------|------|--------------------|
| 454 | 1.8K | 2SA1602A (EF) -TLB |
| C505 | 220 | 2SB1689-TLB |

Bus No. 2 to Schema 2/5 B2/5

except []: 353 series only
***: parts not mounted

3.8 IRKY and PSWB ASSYS

A

B

C

D

E

F

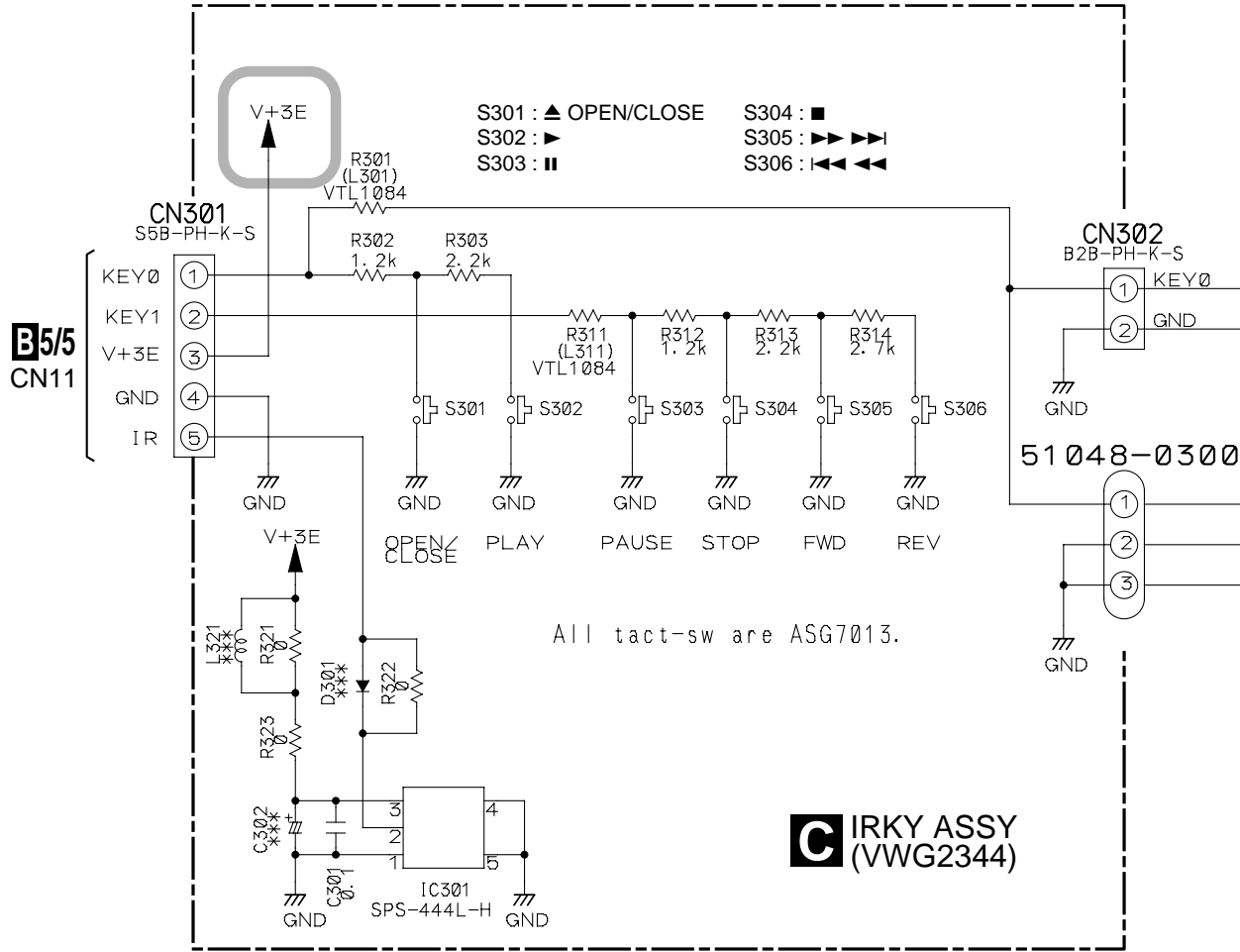

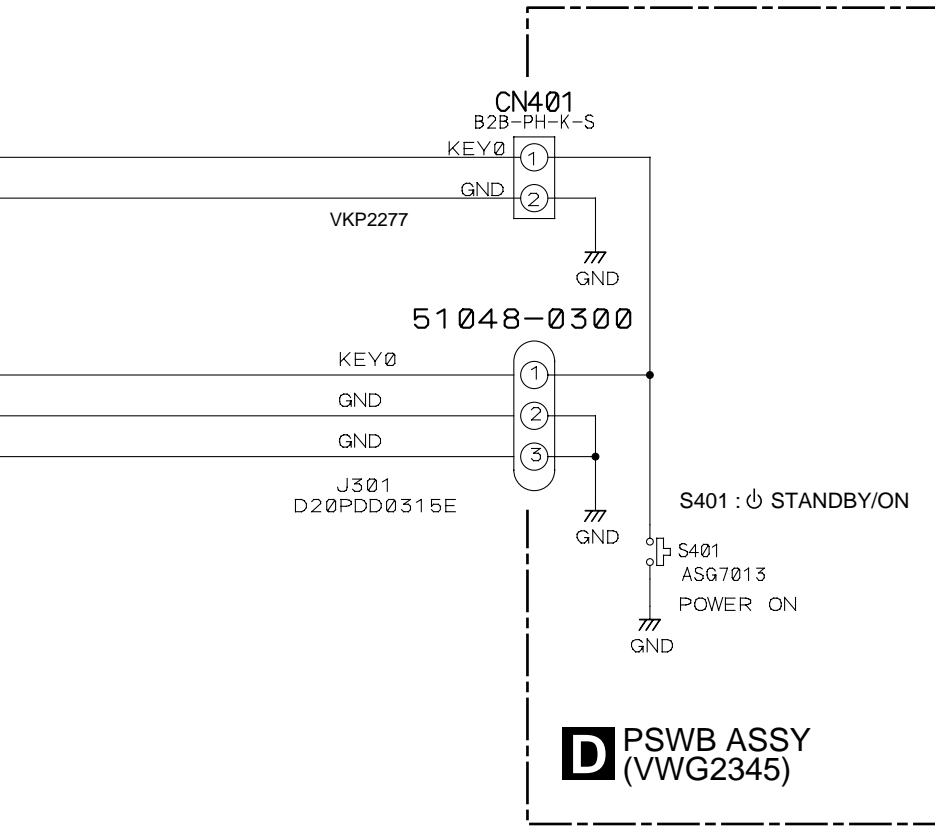

.*** : parts not mounted.

D PSWB ASSY (VWG2345)

| | for OTHERS | for ##XCN type |
|------------|------------|----------------|
| CN302 | × | ○ |
| CN401 | × | ○ |
| J301 | ○ | × |
| 51048-0300 | ○ | × |
| VKP2277 | × | ○ |

 : The power supply is shown with the marked box.

POWER SUPPLY UNIT (VWR1352)

NOTE OF SPARE PARTS IN POWER SUPPLY (SYPS) UNIT

- In case of repairing, use the described parts only to prevent an accident.
- Please write the red ✓ mark on the board when the primary section of POWER SUPPLY (SYPS) Unit is repaired.
- Please take care to keep the space, not touching other parts when replacing the parts.

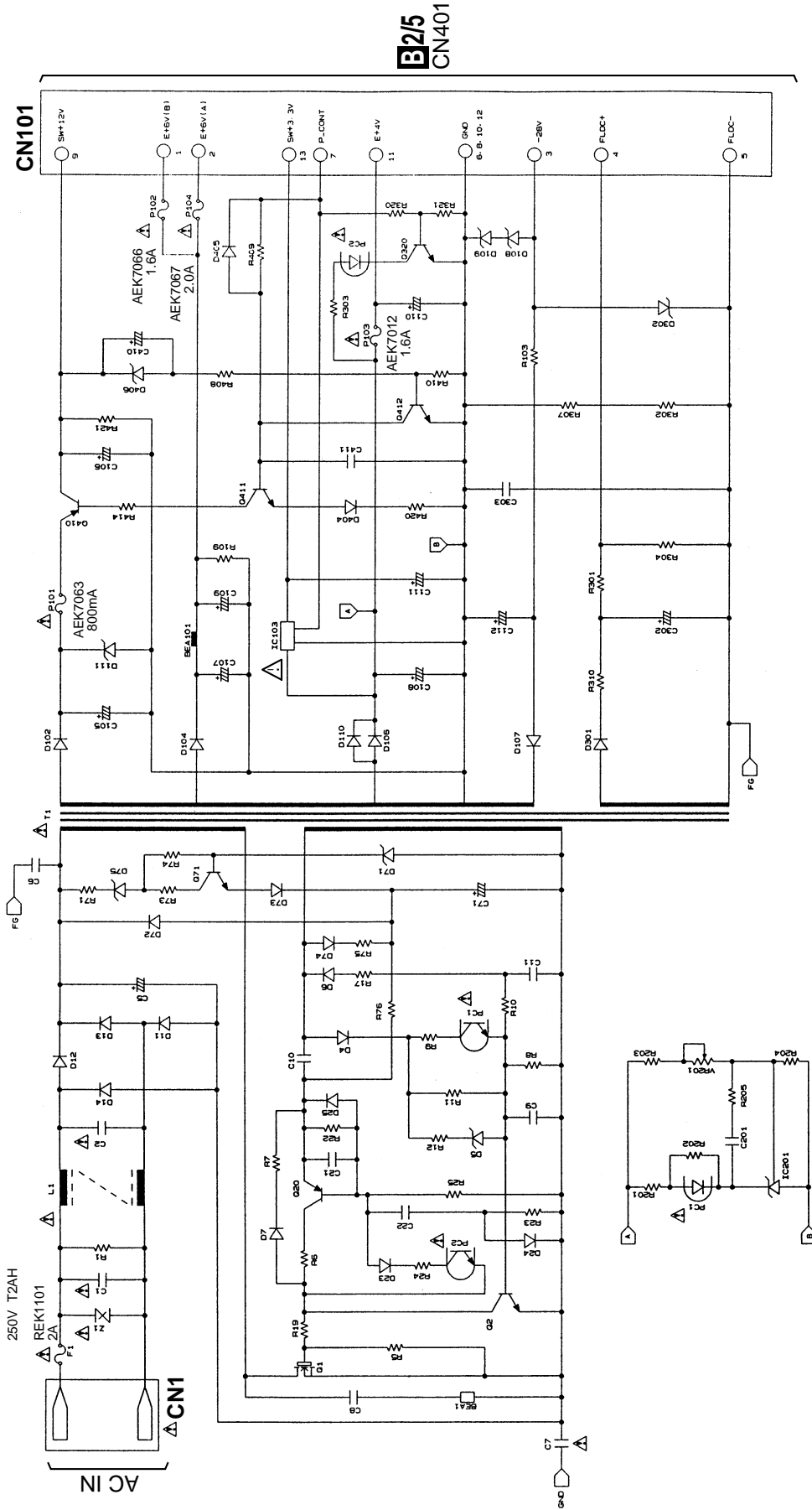

POWER SUPPLY UNIT (VWR1354)

« NOTE OF SPARE PARTS IN POWER SUPPLY (SYPS) UNIT »

- In case of repairing, use the described parts only to prevent an accident.
- Please write the red ✓ mark on the board when the primary section of POWER SUPPLY (SYPS) Unit is repaired.
- Please take care to keep the space, not touching other parts when replacing the parts.

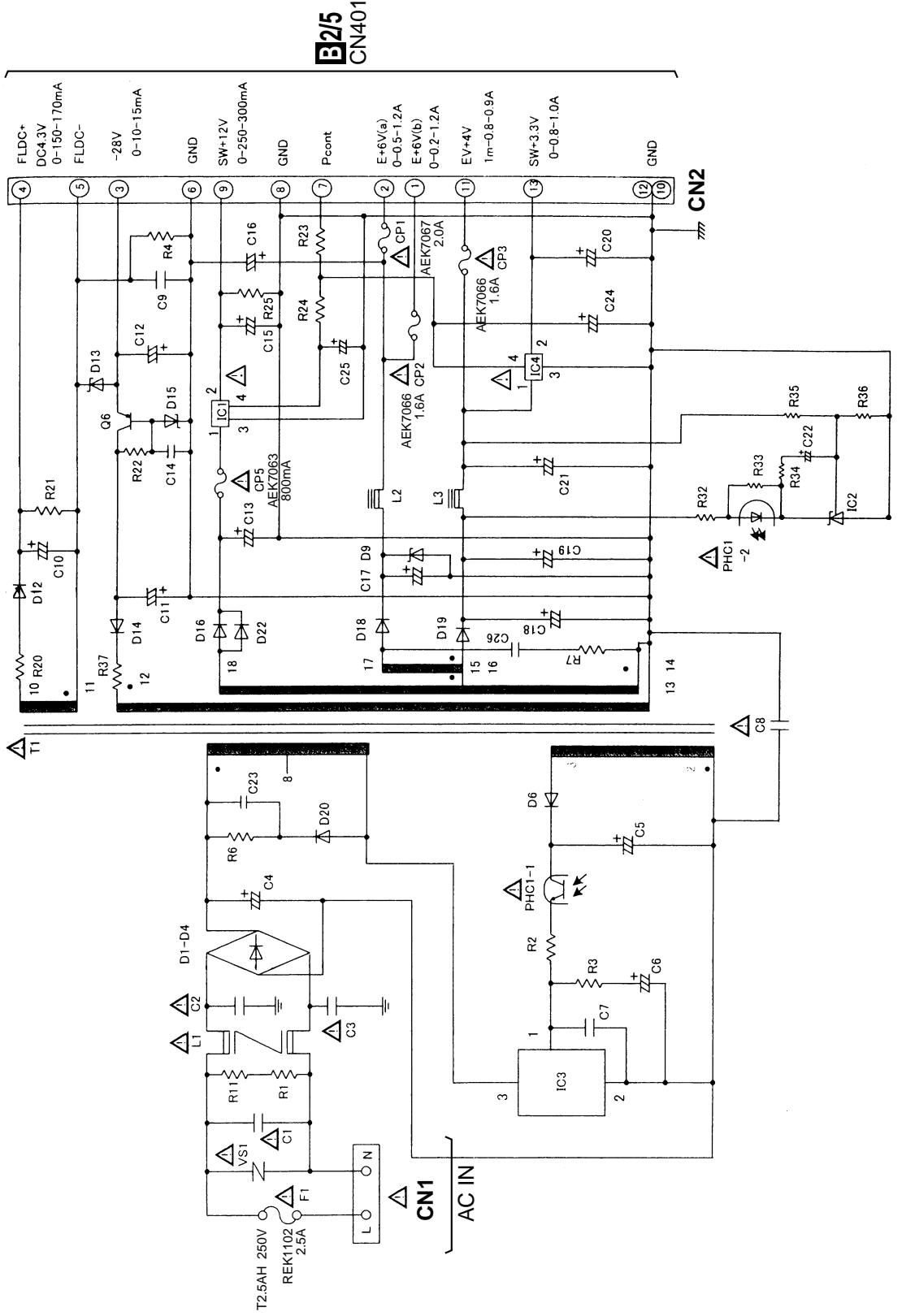

3.11 SCRIB ASSY

G SCRIB ASSY(VWV1903)

A

B

C

D

E

F

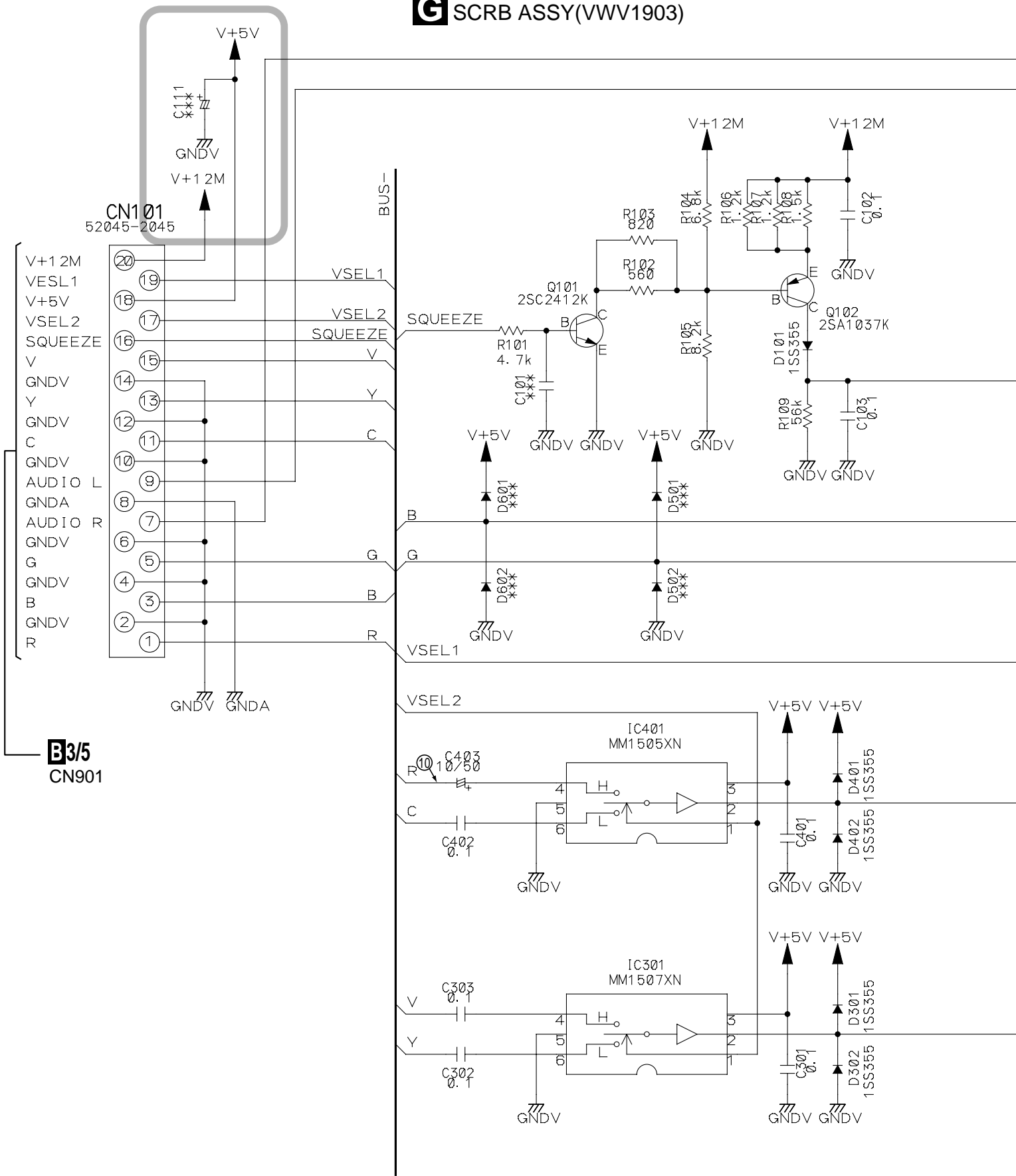

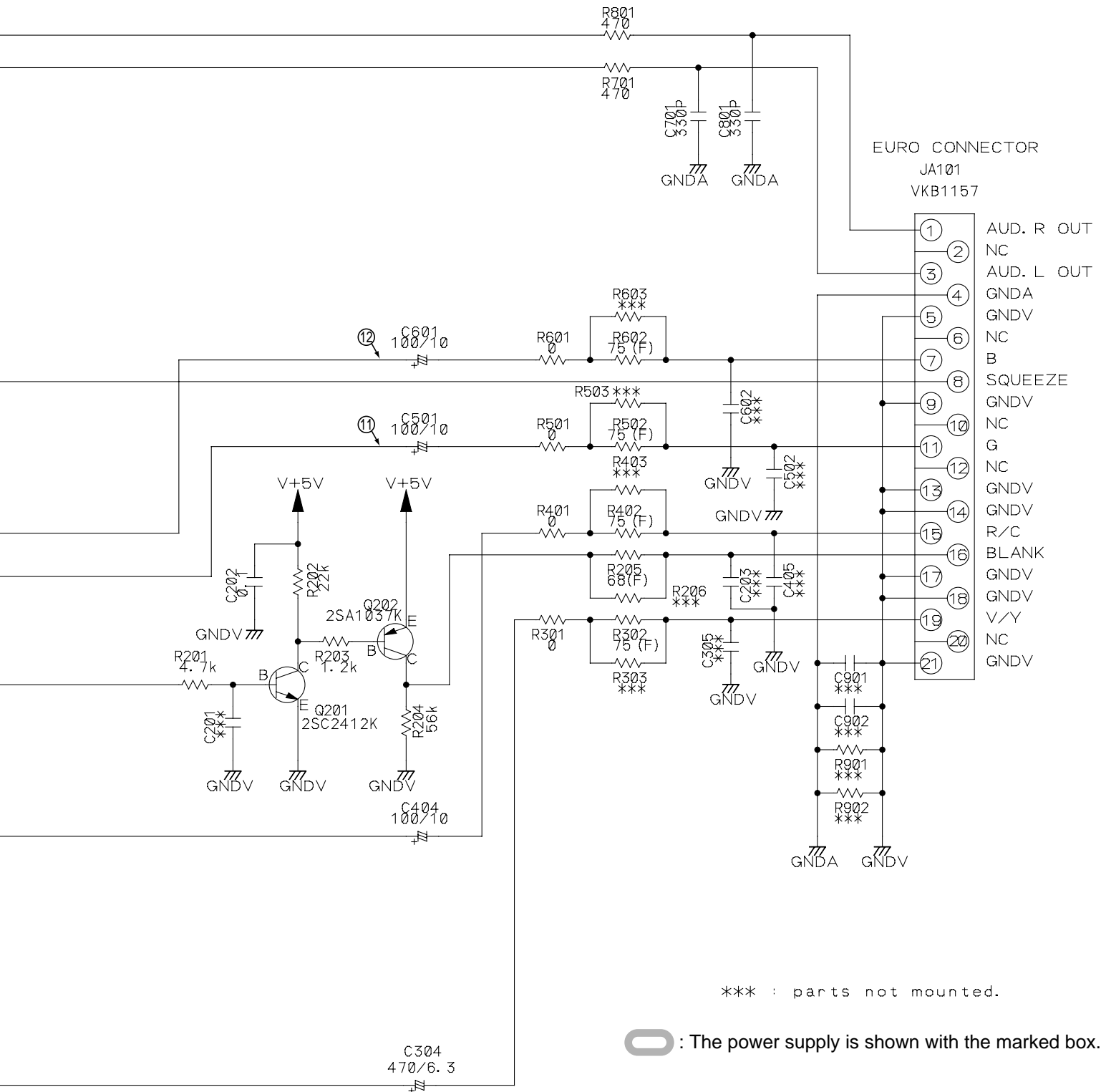

*** : parts not mounted.

 : The power supply is shown with the marked box.

⑩-⑫: Refer to "3.1.3 WAVEFORMS".

1

2

3

4

A

B

C

D

E

F

1

2

3

4

4. PCB CONNECTION DIAGRAM

NOTE FOR PCB DIAGRAMS :

1. Part numbers in PCB diagrams match those in the schematic diagrams.
2. A comparison between the main parts of PCB and schematic diagrams is shown below.

| Symbol In PCB Diagrams | Symbol In Schematic Diagrams | Part Name |
|------------------------|------------------------------|--------------------------|
| | | Transistor |
| | | Transistor with resistor |
| | | Field effect transistor |
| | | Resistor array |
| | | 3-terminal regulator |

3. The parts mounted on this PCB include all necessary parts for several destinations.
For further information for respective destinations, be sure to check with the schematic diagram.
4. View point of PCB diagrams.

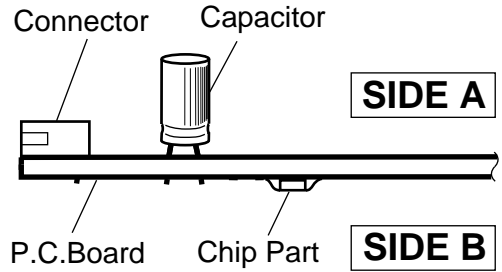

4.1 LOAB ASSY

A LOAB ASSY

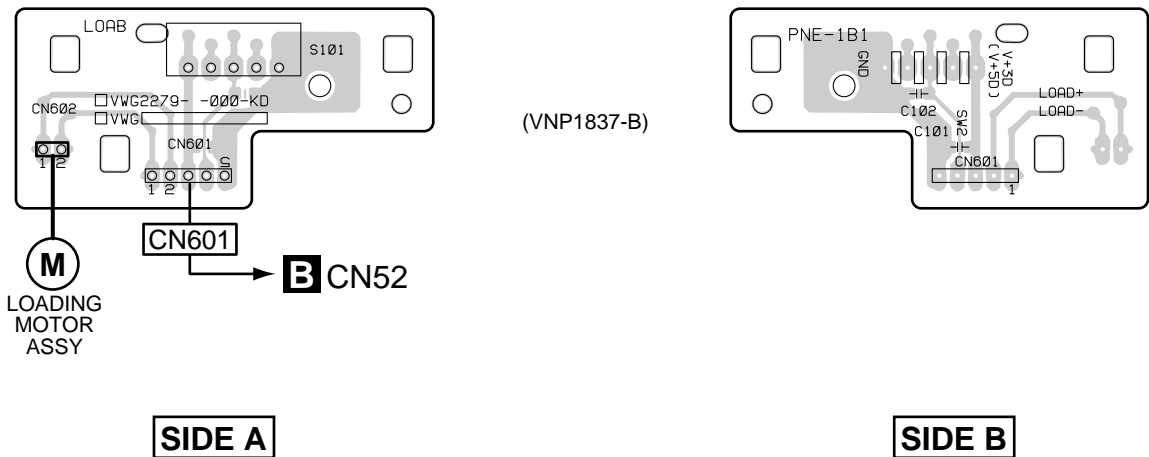

4.2 FJMB ASSY

SIDE A

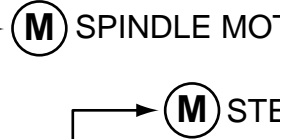

B FJMB ASSY

A CN601

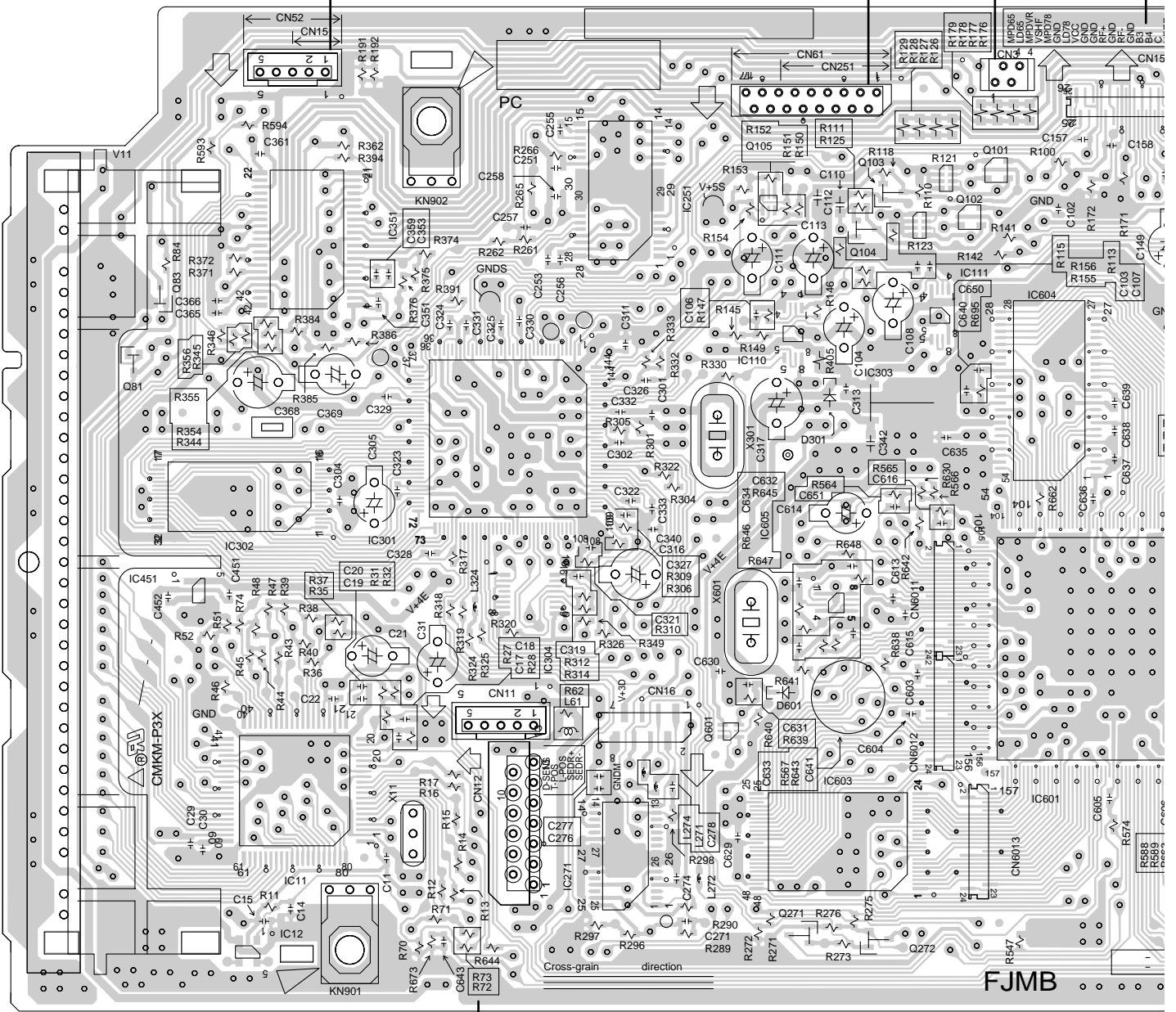

C CN301

(VNP1867-C)

| | | | | | | | | | | | |
|-------|-----|-------|------|-------|-------|-------|-------|-------|-------|-------|-------|
| Q81 | Q83 | IC302 | IC11 | IC351 | IC301 | IC304 | IC271 | IC251 | Q105 | Q103 | Q101 |
| IC451 | | IC12 | | | | | | Q601 | IC110 | IC303 | IC102 |
| | | | | | | | | | Q271 | IC603 | Q272 |
| | | | | | | | | | | | IC604 |
| | | | | | | | | | | | IC601 |

B

SIDE B

A

B

C

D

E

F

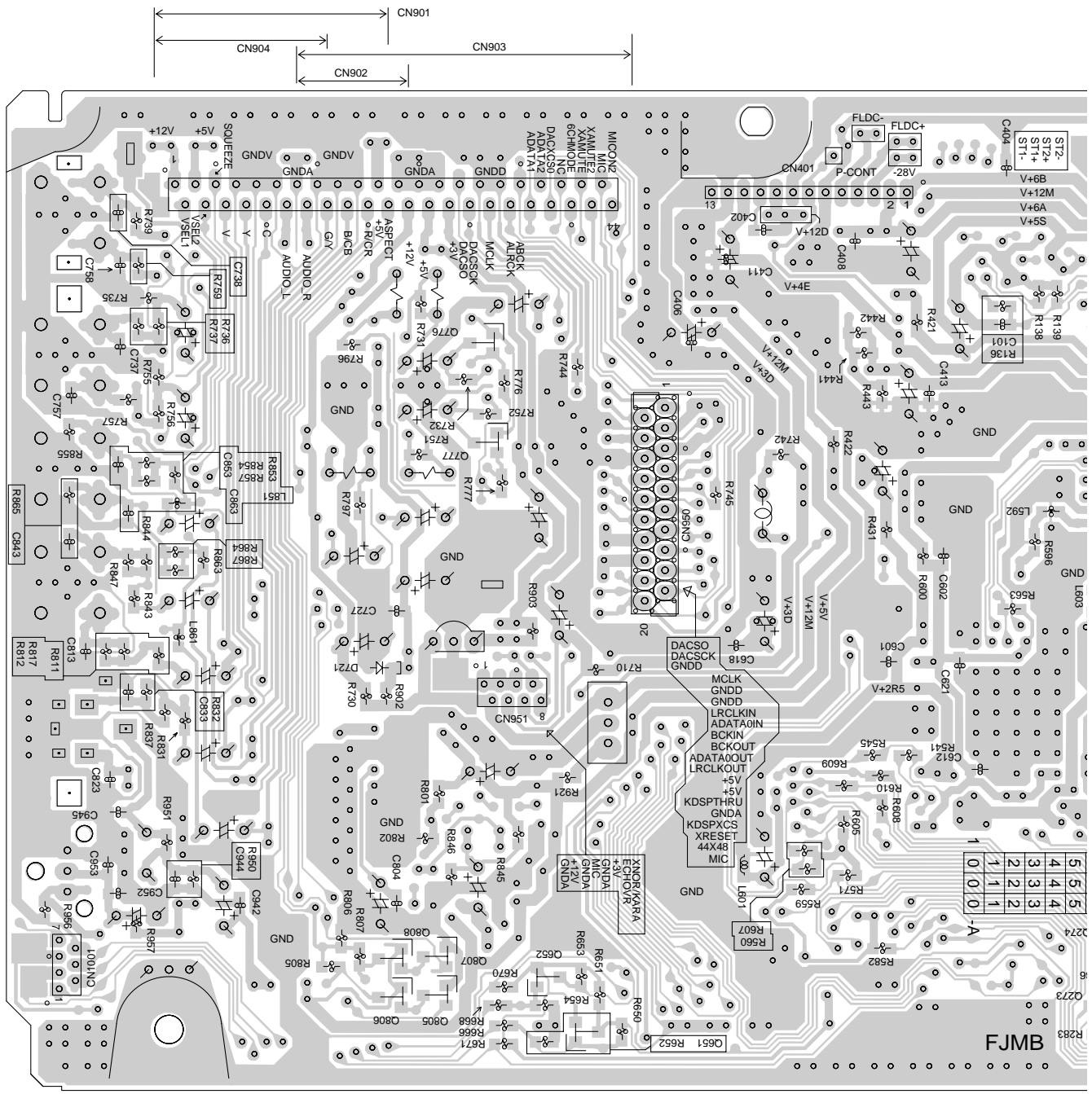

- Q776
- Q777
- Q808 Q807 Q651 Q27
- Q806 Q805 Q651 Q273

B FJMB ASSY

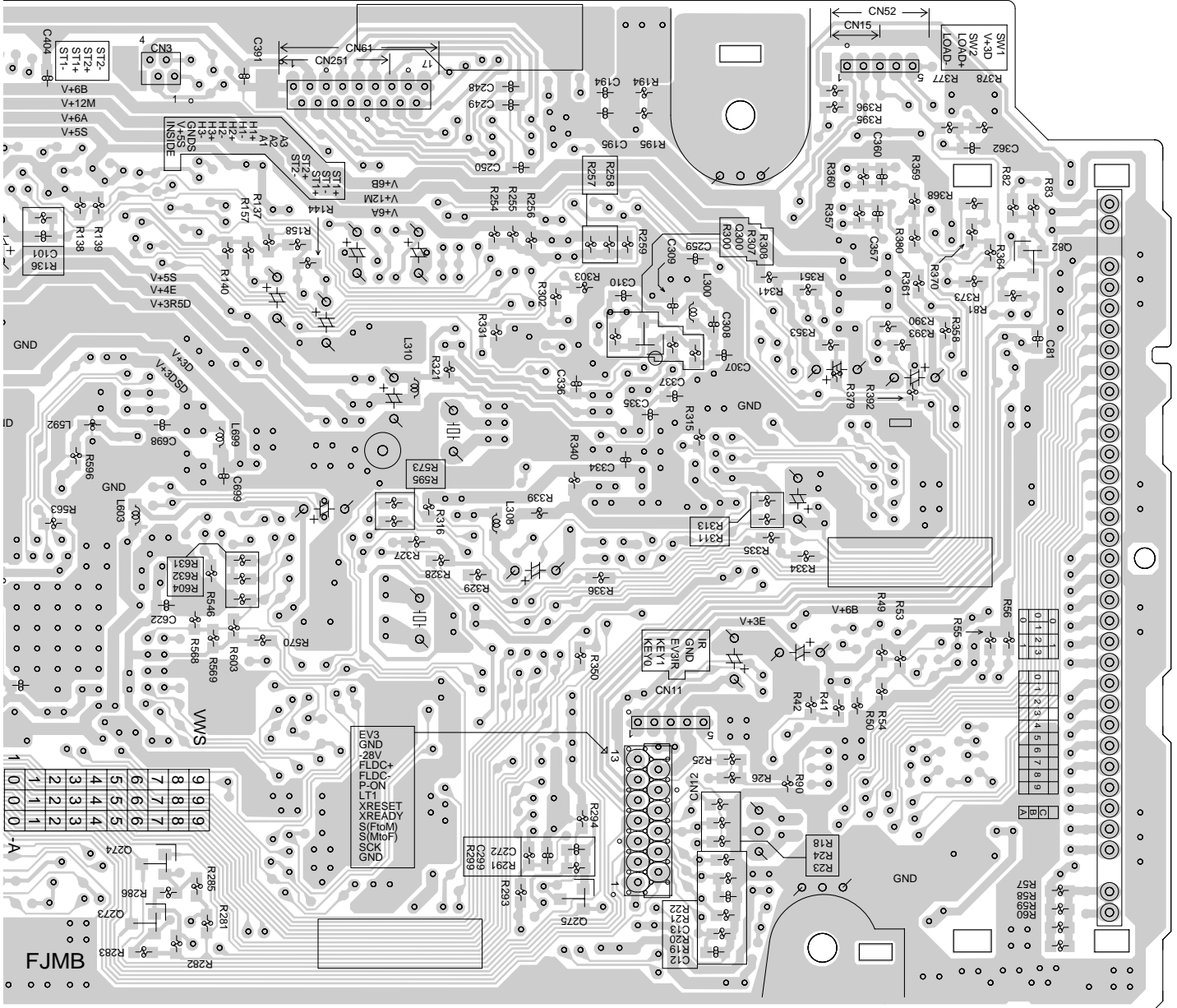

(VNP1867-C)

Q300

Q82

Q274
Q273

Q275

4.3 IRKY and PSWB ASSYS

A

D PSWB ASSY

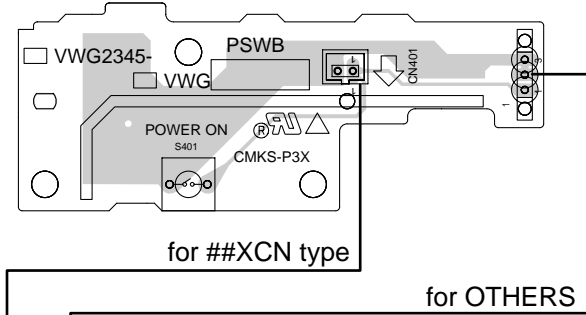

B

C IRKY ASSY

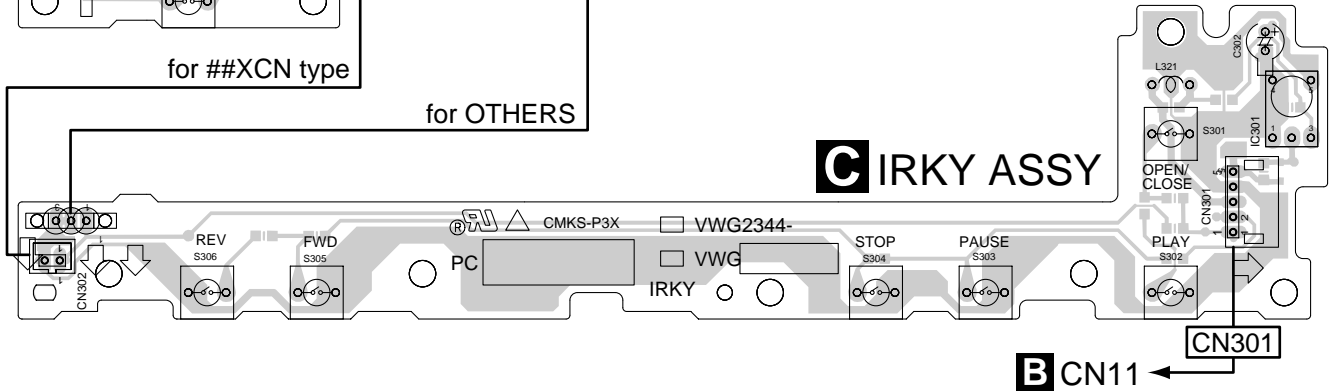

C

SIDE A (VNP1868-B)

SIDE B (VNP1868-B)

D

C IRKY ASSY

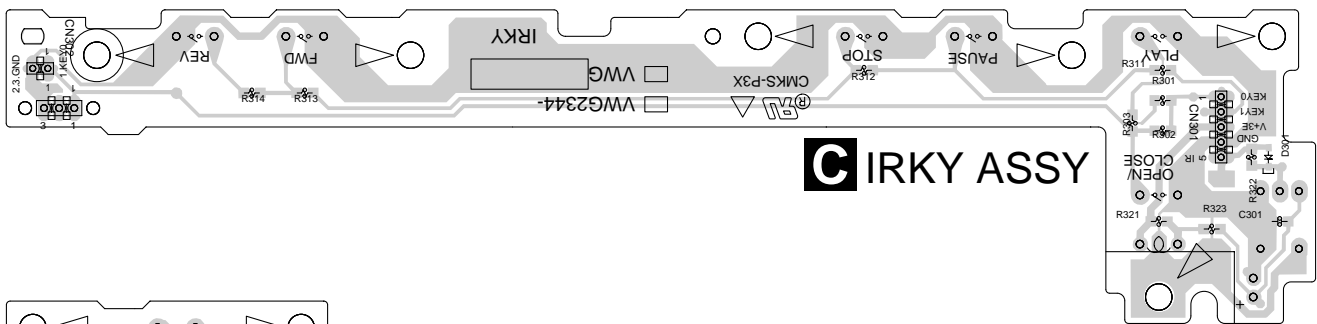

E

D PSWB ASSY

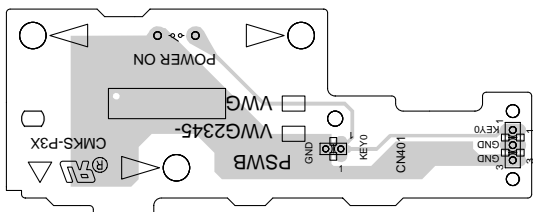

F



4.4 POWER SUPPLY UNIT (VWR1352)

SIDE A

SIDE A

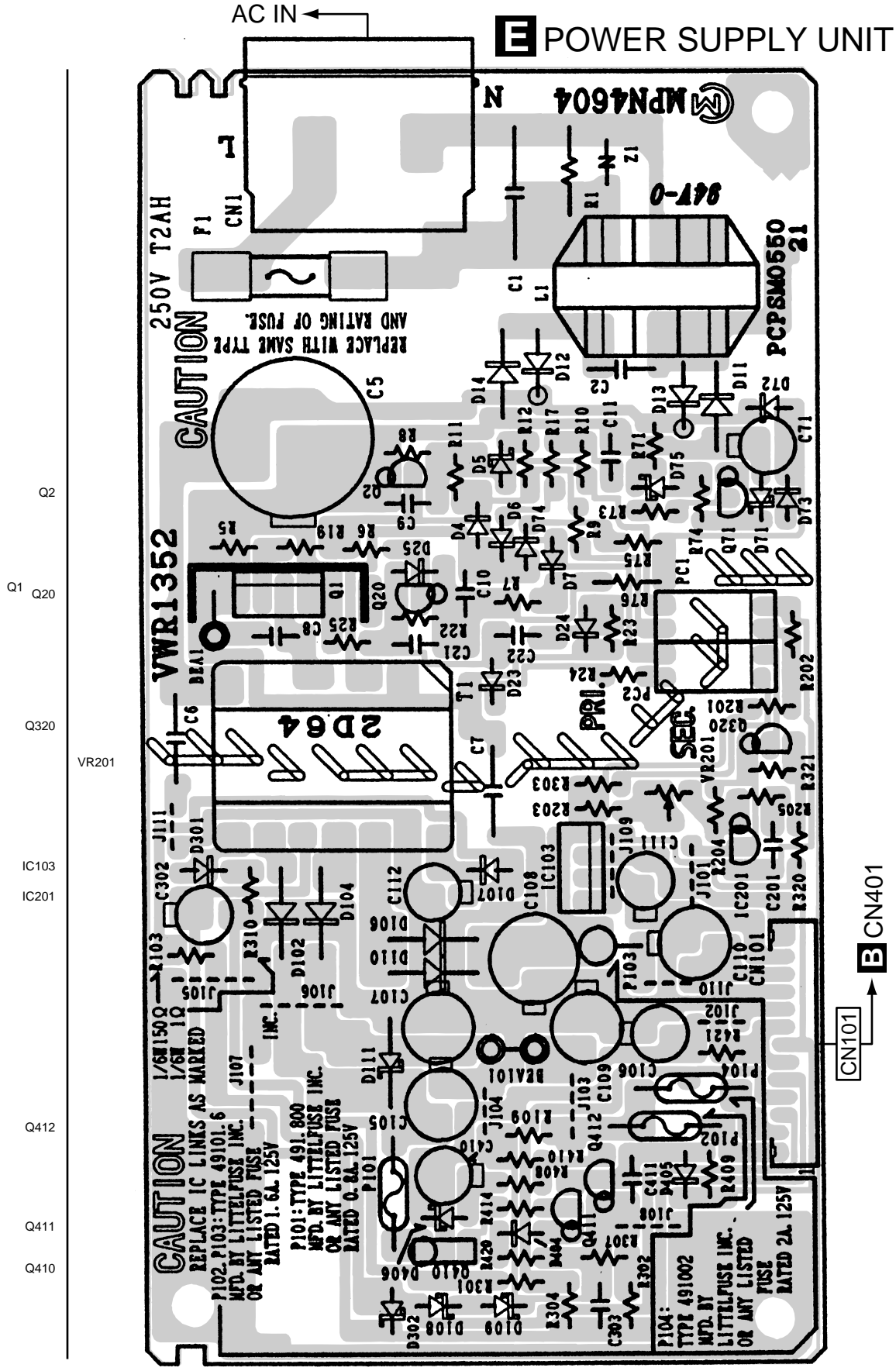

4.5 POWER SUPPLY UNIT (VWR1354)

SIDE A

SIDE A

POWER SUPPLY UNIT

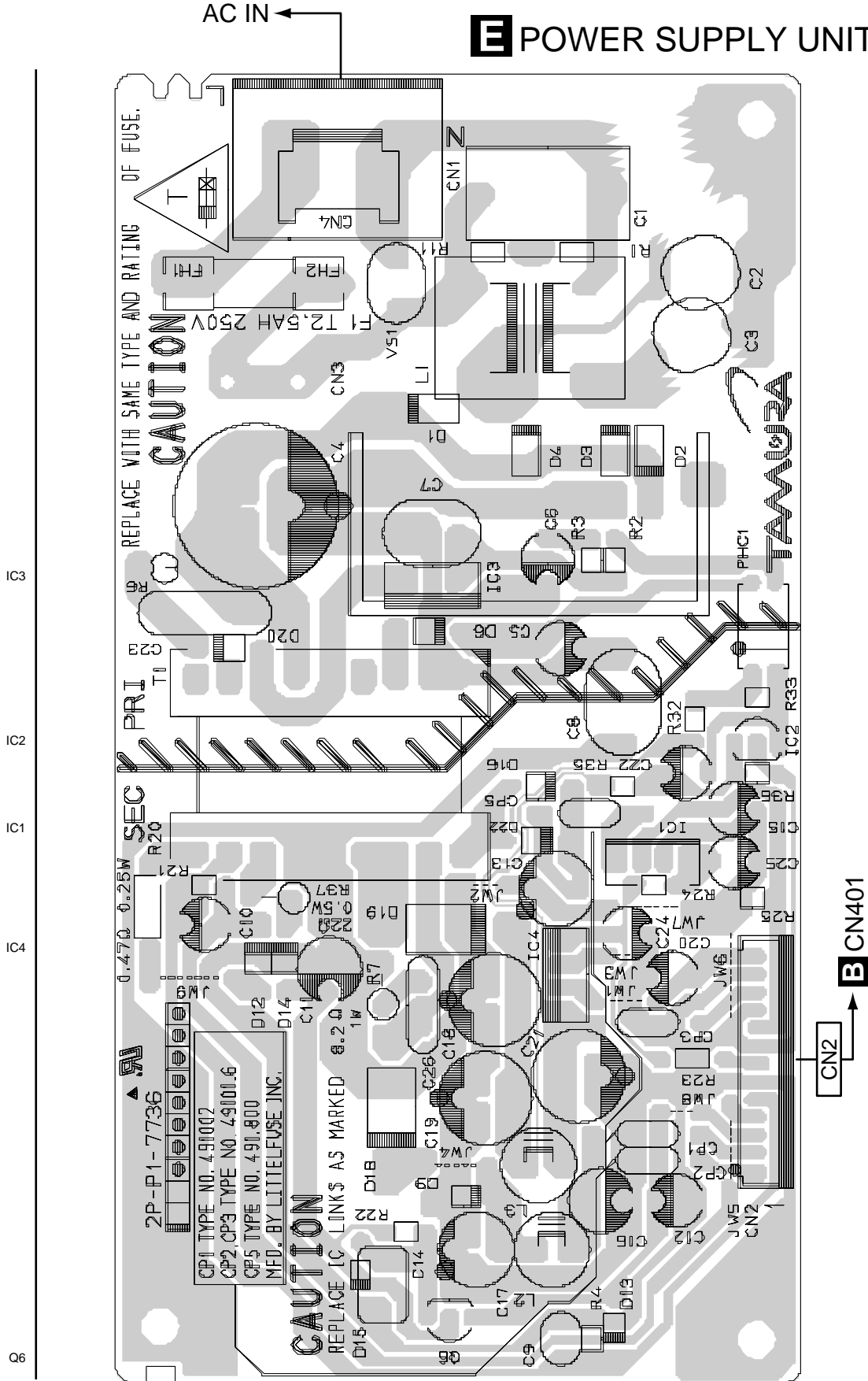

5. PCB PARTS LIST

NOTES: ●Parts marked by "NSP" are generally unavailable because they are not in our Master Spare Parts List.

●The Δ mark found on some component parts indicates the importance of the safety factor of the part.

Therefore, when replacing, be sure to use parts of identical designation.

●When ordering resistors, first convert resistance values into code form as shown in the following examples.

Ex.1 When there are 2 effective digits (any digit apart from 0), such as 560 ohm and 47k ohm (tolerance is shown by J=5%, and K=10%).

560 Ω \rightarrow 56 $\times 10^1$ \rightarrow 561 RD1/4PU $\boxed{5}$ $\boxed{6}$ $\boxed{1}$ J

47k Ω \rightarrow 47 $\times 10^3$ \rightarrow 473 RD1/4PU $\boxed{4}$ $\boxed{7}$ $\boxed{3}$ J

0.5 Ω \rightarrow R50 RN2H \boxed{R} $\boxed{5}$ $\boxed{0}$ K

1 Ω \rightarrow 1R0 RS1P $\boxed{1}$ \boxed{R} $\boxed{0}$ K

Ex.2 When there are 3 effective digits (such as in high precision metal film resistors).

5.62k Ω \rightarrow 562 $\times 10^1$ \rightarrow 5621 RN1/4PC $\boxed{5}$ $\boxed{6}$ $\boxed{2}$ $\boxed{1}$ F

| Mark | No. | Description | Part No. | Mark | No. | Description | Part No. |
|---------------------------|-----|------------------------|-------------------------|-----------------------|----------------------------|-------------|----------|
| LIST OF ASSEMBLIES | | | | PCB PARTS LIST | | | |
| NSP | 1.. | LOADING MECHANISM ASSY | VWT1197 | A | LOAB ASSY | | |
| NSP | 2.. | LOAB ASSY | VWG2279 | | SWITCHES AND RELAYS | | |
| | 1.. | FJMB ASSY | VWS1518 | S101 | REAF SWITCH | VSK1011 | |
| NSP | 1.. | KEYB ASSY | VWM2122 | OTHERS | | | |
| NSP | 2.. | IRKY ASSY | VWG2344 | CN602 | CONNCTOR | S2B-PH-K | |
| NSP | 2.. | PSWB ASSY | VWG2345 | CN601 | CONNCTOR | S5B-PH-K | |
| Δ | 1.. | POWER SUPPLY UNIT | VWR1354 (or VWR1352) | | PRINTED CIRCUIT BOARD | VNP1837 | |
| | 1.. | SCRB ASSY | VWV1903 | | | | |

B FJMB ASSY

SEMICONDUCTORS

| | | |
|----------|------------------------|-----------------|
| Δ | IC110 | BA10358FV |
| | IC303 | BA18BC0FP |
| | IC731 | BA4560F |
| | IC251 | BA6664FM |
| | IC604 | K4S641632F-TC75 |
| | IC302 | K6T1008V2E-TB70 |
| | IC301 | L6315ATXXTY |
| | IC351 | M56788AFP |
| Δ | IC451 | MM1385EN |
| Δ | IC421 | MM1565AF |
| | IC801 | MM1567AJ |
| Δ | IC901 | NJM78L05A |
| | IC711 | PCM1742KE |
| | IC11 | PE5314B |
| Δ | IC431 | PQ025EZ01ZP |
| Δ | IC441 | PQ070XZ02ZP |
| | IC12 | PST3228 |
| | IC601 | STI5519AVB-B0C |
| | IC605 | TC7WU04FU |
| | IC603 | VYW1978 |
| | Q300, Q602-Q607, Q762 | 2SA1037K |
| | Q81, Q83 | 2SA1602A |
| | Q103, Q104, Q82, Q941 | 2SC2412K |
| | Q766-Q769 | 2SD2114K |
| | Q652 | DTC114TK |
| | Q711, Q761, Q805, Q807 | DTC114YK |
| | Q101, Q102 | HN1A01F |
| | Q806, Q808 | PDTA124EK |
| | Q601 | RN4982 |
| | D601 | RB501V-40 |
| | D721 | UDZS6.2B |

| Mark No. | Description | Part No. |
|------------------------------|-------------|---------------|
| COILS AND FILTERS | | |
| L741 | | LAU3R3J |
| L699 | | LCYA2R2J2520 |
| L300 | | LCYA2R7J2520 |
| L324 | CHIP BEADS | VTL1083 |
| CAPACITORS | | |
| C301, C302 | | CCSRCH100D50 |
| C310 | | CCSRCH151J50 |
| C307 | | CCSRCH180J50 |
| C360 | | CCSRCH330J50 |
| C391, C737, C757 | | CCSRCH331J50 |
| C351 | | CCSRCH470J50 |
| C309 | | CCSRCH560J50 |
| C308 | | CCSRCH7R0D50 |
| C633, C634 | | CCSRCH8R0D50 |
| C113 | | CEAT100M50 |
| C104, C21, C316, C317, C368 | | CEAT101M10 |
| C405, C412, C432, C614, C711 | | CEAT101M10 |
| C721, C726, C731, C736, C751 | | CEAT101M10 |
| C756, C801, C803 | | CEAT101M10 |
| C617, C714 | | CEAT102M6R3 |
| C943 | | CEAT1R0M50 |
| C111 | | CEAT220M25 |
| C724 | | CEAT470M16 |
| C812, C832 | | CEAT471M6R3 |
| C342, C422 | | CKSQYB225K10 |
| C699 | | CKSQYF225Z16 |
| C14, C340, C641 | | CKSRYB102K50 |
| C259, C311 | | CKSRYB103K50 |
| C248-C251, C255 | | CKSRYB104K16 |
| C257, C258 | | CKSRYB223K50 |
| C733, C753 | | CKSRYB272K50 |
| C357 | | CKSRYB472K50 |
| C106, C11, C148, C157, C158 | | CKSRYF104Z25 |
| C22, C253, C256, C304 | | CKSRYF104Z25 |
| C321-C333, C365, C366, C451 | | CKSRYF104Z25 |
| C602-C609, C612, C618 | | CKSRYF104Z25 |
| C621, C622, C632, C637-C640 | | CKSRYF104Z25 |
| C713, C717, C722, C725, C735 | | CKSRYF104Z25 |
| C755, C802, C804, C805, C811 | | CKSRYF104Z25 |
| C821, C822, C831, C844, C851 | | CKSRYF104Z25 |
| C861, C952 | | CKSRYF104Z25 |
| C30 | | CKSRYF104Z50 |
| C411, C423, C431, C601 | | CKSRYF105Z10 |
| C610, C611, C613, C615, C629 | | CKSRYF105Z10 |
| C635, C636, C741 | | CKSRYF105Z10 |
| C734, C754 (330P/50V) | | VCH1226 |
| RESISTORS | | |
| R121 | | RAB4C220J |
| R123 | | RAB4C390J |
| R731, R751 | | RN1/16SE2201D |
| R734, R754 | | RN1/16SE4301D |
| R341 | | RS1/10S101J |
| R764 | | RS1/10S182J |
| R126-R129, R176-R179 | | RS1/10S220J |
| R254-R259 | | RS1/10S3R3J |
| R822, R832 | | RS1/10S75R0F |
| R326-R330, R443 | | RS1/16S1001F |

| Mark No. | Description | Part No. |
|------------------------------|-------------|--------------|
| R147, R265, R266, R304, R322 | | RS1/16S1002F |
| R377, R378, R392, R393 | | RS1/16S1002F |
| R344, R351, R353, R354 | | RS1/16S1003D |
| R359, R360, R368, R372 | | RS1/16S1003D |
| R374, R375, R384, R385 | | RS1/16S1003D |
| R335, R336 | | RS1/16S1003F |
| R302 | | RS1/16S1202F |
| R358, R394 | | RS1/16S1503F |
| R146, R441 | | RS1/16S1801F |
| R612, R613 | | RS1/16S1802F |
| R442 | | RS1/16S1803F |
| R675, R678, R681, R684, R687 | | RS1/16S2700F |
| R690 | | RS1/16S2700F |
| R345, R355, R370, R371 | | RS1/16S3902F |
| R346, R356, R357, R362, R364 | | RS1/16S6802F |
| R373 | | RS1/16S6802F |
| R812 | | RS1/16S75R0F |
| R390 | | RS1/16S8202F |
| OtherResistors | | RS1/16S###J |

OTHERS

| | |
|---------------------------|------------|
| CN901 20P CONNECTOR | 52045-2045 |
| CN401 CONNECTOR | B13B-PH-K |
| CN11, CN52 CONNECTOR POST | B5B-PH-K |
| JA950 | JFJ1001 |
| OPT. LINK OUT 8MB/S | |
| V11 FL TUBE | VAW1070 |
| FLEXIBLE CABLE | VDA1681 |
| PCB BINDER | VEF1040 |
| JA701 JACK | VKB1180 |
| CN3 4P CONNECTOR | VKN1180 |
| CN251 12P CONNECTOR | VKN1188 |
| CN1001 7P CONNECTOR | VKN1211 |
| CN151 26P CONNECTOR | VKN1790 |
| FL HOLDER | VNK4980 |
| X11 (5MHz) | VSS1142 |
| X301 (20MHz) | VSS1167 |
| X601 (27MHz) | VSS1168 |

CIRKY ASSY**SEMICONDUCTORS**

| | |
|-------|------------|
| IC301 | SPS-444L-H |
|-------|------------|

COILS AND FILTERS

| | |
|------------|---------|
| L301, L311 | VTL1084 |
|------------|---------|

SWITCHES AND RELAYS

| | |
|-----------|---------|
| S301-S306 | ASG7013 |
|-----------|---------|

CAPACITORS

| | |
|------|--------------|
| C301 | CKSRYF104Z25 |
|------|--------------|

RESISTORS

| | |
|---------------|-------------|
| All Resistors | RS1/16S###J |
|---------------|-------------|

OTHERS

| | |
|---------------------|-------------|
| 3P CABLE HOLDER | 51048-0300 |
| J301 3P JUMPER WIRE | D20PDD0315E |
| CN301 CONNECTOR | S5B-PH-K |

Mark No. Description Part No.

D PSWB ASSY

SWITCHES AND RELAYS

S401 ASG7013

OTHERS

3P CABLE HOLDER 51048-0300

E POWER SUPPLY UNIT (VWR1352)

OTHERS

| | | |
|---|------------------------|---------|
| ⚠ | P103 PROTECTOR (1.6A) | AEK7012 |
| ⚠ | P101 PROTECTOR (800mA) | AEK7063 |
| ⚠ | P102 PROTECTOR (1.6A) | AEK7066 |
| ⚠ | P104 PROTECTOR (2A) | AEK7067 |
| ⚠ | F1 FUSE (2A) | REK1101 |

E POWER SUPPLY UNIT (VWR1354)

OTHERS

| | | |
|---|---------------------------|---------|
| ⚠ | CP5 PROTECTOR (800mA) | AEK7063 |
| ⚠ | CP2, CP3 PROTECTOR (1.6A) | AEK7066 |
| ⚠ | CP1 PROTECTOR (2A) | AEK7067 |
| ⚠ | F1 FUSE (2.5A) | REK1102 |

G SCRB ASSY

SEMICONDUCTORS

| | |
|------------------------------|----------|
| IC401 | MM1505XN |
| IC301 | MM1507XN |
| Q102, Q202 | 2SA1037K |
| Q101, Q201 | 2SC2412K |
| D101, D301, D302, D401, D402 | 1SS355 |

CAPACITORS

| | |
|-----------------------------|--------------|
| C701, C801 | CCSRCH331J50 |
| C403 | CEAT100M50 |
| C404, C501, C601 | CEAT101M10 |
| C304 | CEAT471M6R3 |
| C102, C103, C202, C301-C303 | CKSRYF104Z25 |
| C401, C402 | CKSRYF104Z25 |

RESISTORS

| | |
|------------------------|--------------|
| R301, R401, R501, R601 | RS1/10S0R0J |
| R205 | RS1/10S68R0F |
| R302, R402, R502, R602 | RS1/10S75R0F |
| OtherResistors | RS1/16S###J |

OTHERS

| | |
|---------------------|------------|
| CN101 20P CONNECTOR | 52045-2045 |
| JA101 CONNECTOR | VKB1157 |

6. ADJUSTMENT

6.1 ADJUSTMENT ITEMS AND LOCATION

■ Adjustment Items

[Mechanism Part]

- ① Tangential and Radial Height Coarse Adjustment
- ② DVD Jitter Adjustment
- ③ Initialize the Focus Sweep Setting

[Electrical Part]



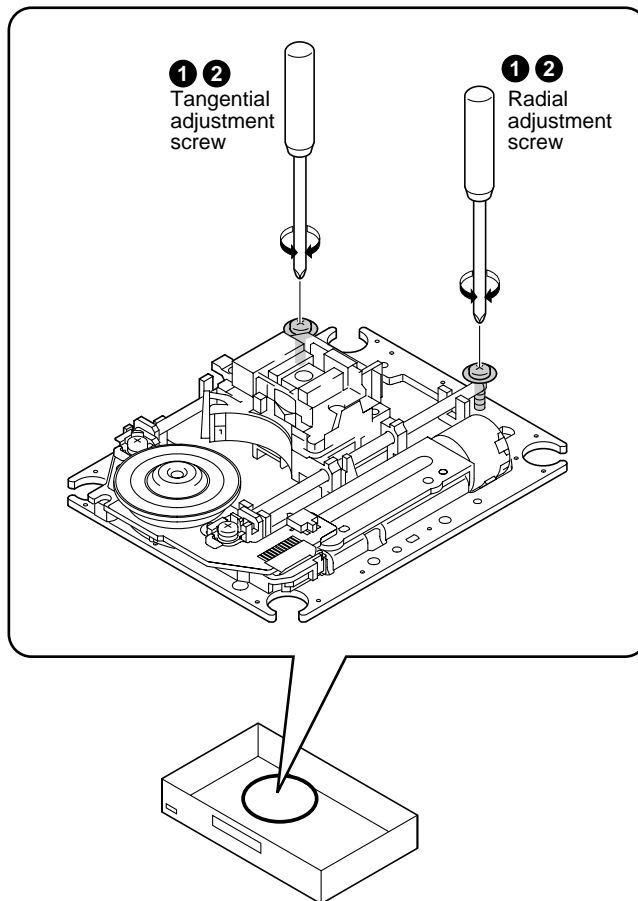

Electrical adjustments are not required.

■ Adjustment Points (Mechanism Part)

Cautions: After adjustment, adjustment screw locks with the Screw tight.

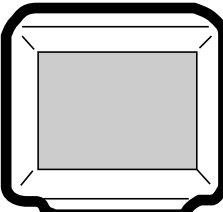
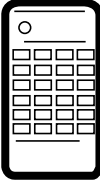

6.2 JIGS AND MEASURING INSTRUMENTS

| | | | |
|------------------------------------------------------------------------------------------------------------------|--------------------------------------------------------------------------------------------------------------------|--------------------------------------------------------------------------------------------------------|--------------------------------------------------------------------------------------------------------------------------------------|
|  <p>⊕ Screwdriver (large)</p> |  <p>⊕ Screwdriver (medium)</p> |  <p>TV monitor</p> |  <p>Test mode remote control unit (GGF1067)</p> |
|  <p>⊕ Precise screwdriver</p> |  <p>DVD test disc (GGV1025)</p> | <p>Screw tight (GYL1001)</p> | |

6.3 NECESSARY ADJUSTMENT POINTS

When

Adjustment Points

■ Exchange Parts of Mechanism Assy

| | | | | |
|---|---------------------------------|------------------|---------|-------------------------------------------------------|
| A | Exchange the Pickup | Mechanical point | ①, ②, ③ | * After adjustment, screw locks with the Screw tight. |
| | | Electric point | _____ | |
| B | Exchange the Traverse Mechanism | Mechanical point | ③ | |
| | | Electric point | _____ | |
| C | Exchange the Spindle Motor | Mechanical point | ②, ③ | * After adjustment, screw locks with the Screw tight. |
| | | Electric point | _____ | |

■ Exchange PCB Assy

| | | | |
|---|--------------------------------------|------------------|-------|
| D | Exchange PC Board LOAB, FJMB ASSY | Mechanical point | _____ |
| | | Electric point | _____ |

*

Purpose: To set the sweep which was correct with the individual Traverse mechanism.

Be sure to perform the following step finally when replaced Pickup, Traverse Mechanism and Spindle Motor.

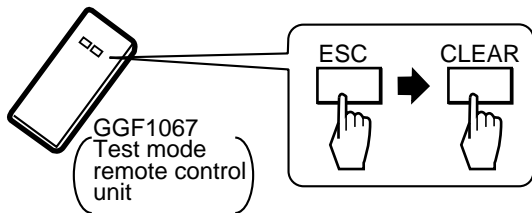

(It is necessary when performed adjustment procedure ②.)

6.4 TEST MODE

TEST MODE: ON

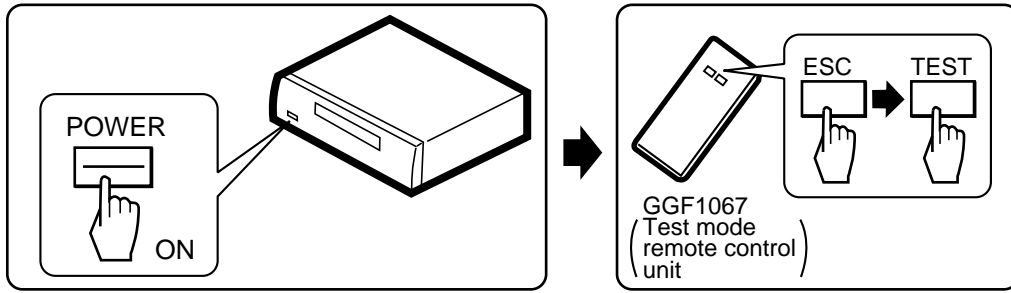

TEST MODE: DISC SET

<TRAY OPEN>

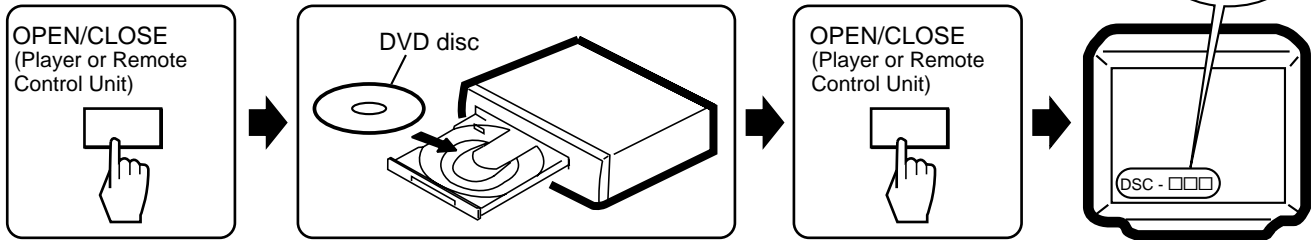

TEST MODE: PLAY

<PLAY>

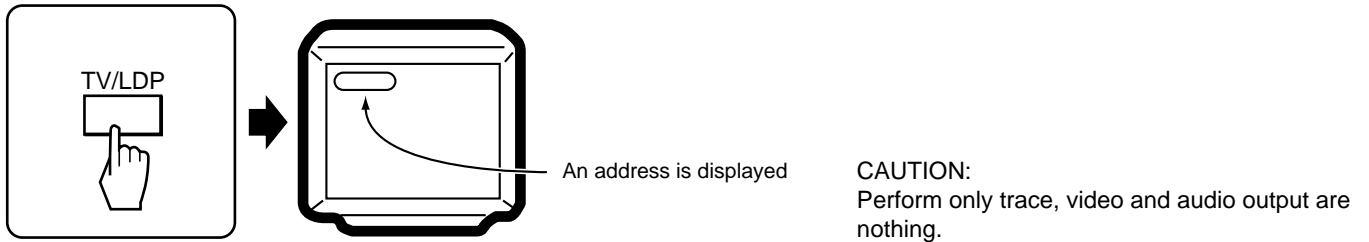

< When playback with the target address of disc (DVD)>

For example, when playback with # 30000

During PLAY +10 → 3 → 0 → 0 → 0 → 0 → CHP/TIM Press keys in order

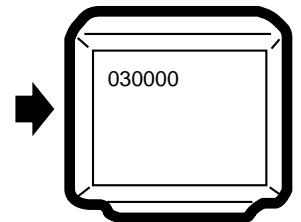

TEST MODE: OFF

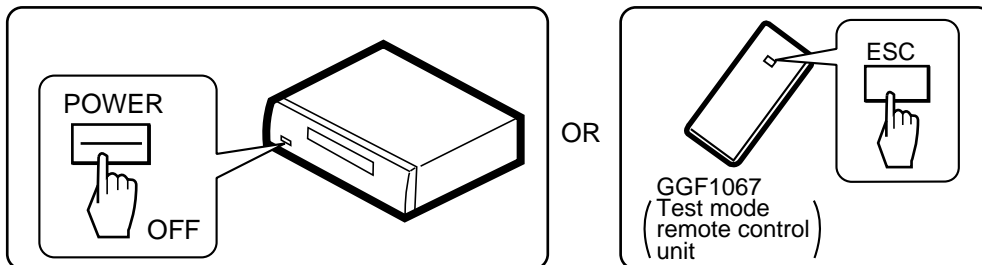

6.5 MECHANISM ADJUSTMENT



1 Tangential and Radial Height Coarse Adjustment

START

- Remove the servo mechanism.
- Remove a Spacer for height adjustment attached to the back side (shaded area) of the Servo Mechanism (Float Base) with nippers.

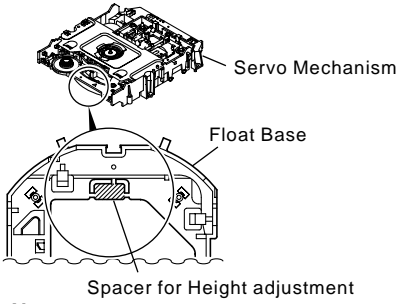

Note:
Turn the Short switch to Short side when removing the Pickup Flexible Cable. (Refer to "7.1.6 DISASSEMBLY".)



Cautions:

Because there is not a Spacer for height adjustment in adjustment after the second time, will keep it at need. (This parts is Traverse mechanism exclusive use of a model for 2001 years)

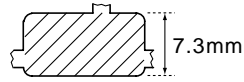

Put a spacer between a Tangential (or Radial) adjustment screw and Mechanism Base and turn each screw to adjust the height. (Refer to "6.1 ADJUSTMENT ITEMS AND LOCATION".)

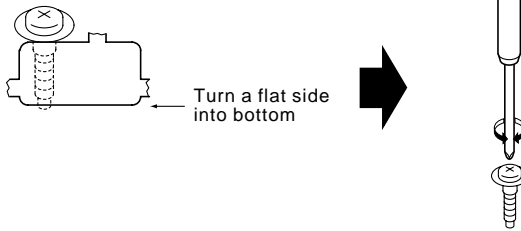

2 DVD Jitter Adjustment

- Playback method of inner and outer address for the purpose is referred to "6.4 TEST MODE".
- Jitter indication of the monitor is referred to "7.1.1 TEST MODE (Display Specification of the Test Mode)".

Use disc: GGV1025

START

- Test mode
- Play the DVD test disc at outer track (around #200000)

Mechanism Assy
Adjust the Tangential Adjustment Screw so that jitter becomes minimum.

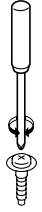

J : Min

- Play the DVD test disc at inner track (around #30000)

Mechanism Assy
Adjust the Radial Adjustment Screw so that jitter becomes minimum.



J : Min

- Play the DVD test disc at outer track (around #200000)

Mechanism Assy
Readjust the Tangential Adjustment Screw so that jitter becomes minimum.



J : Min

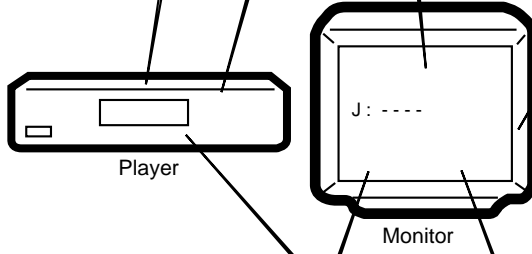

Turn the POWER OFF in case of NG once, and perform the adjustment once again.

CHECK

Confirm the error rate that is displayed "OK"
(Example ERROR RATE: 6.60e - 6 OK)

If error rate is OK, locks a root of tangential and radial adjustment screws with the Screw tight, and go to step 3.
Screw tight: GYL1001



Disc playback normally.
• The measurement of block error rate



ESC

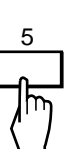

5

Test mode end



ESC

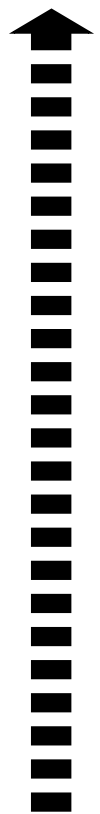

A

3 Initialize the Focus Sweep Setting

Purpose: To set the sweep which was correct with the individual Traverse mechanism.

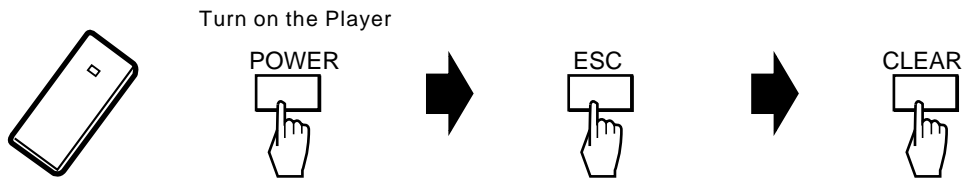

Turn on the Player

Note: Be sure to perform this step when replaced the Pickup or Traverse mechanism.

B

C

D

E

F

7. GENERAL INFORMATION

7.1 DIAGNOSIS

7.1.1 TEST MODE

■ Test Mode Functional Specification

① Test mode entry

In the power ON state, press the [ESC] (A8-5F) key and [TEST / RANDOM] (A8-5E) key in order of the LD remote control unit.

- Light the all FL and LEDs, and goes out the FL and LEDs when pressing the keys of something.
- OSD displays test mode. Refer to the "Display Specification of the Test Mode".

② Release the Test mode

- Turn off the power.
- Press the [ESC] (A8-5F) key of the remote control unit and reset it.

③ Tray open / close

- Press the [REPEAT A-B] (A8 - 48) key of the remote control unit.
- Press the [OPEN / CLOSE] key of the main unit from the stop state.

④ Playback stop

- Press the [REPEAT] (A8 - 44) key of the remote control unit from the playback state.

⑤ LD ON

DVD : Press the [TEST] (A8-5E) and [1] (A8-01) keys in order, and turn on the laser diode (650nm).

CD : Press the [TEST] (A8-5E) and [4] (A8-04) keys in order, and turn on the laser diode (780nm).

⑥ Focus on / sweep

1. Lock the focus by pressing the [TEST] (A8-5E) and [2] (A8-02) keys in order.
2. Repeat focus sweep by pressing the [TEST] (A8-5E) and [3] (A8-03) keys in order.

⑦ Spindle FG servo

CAV : Press the [TEST] (A8-5E) and [5] (A8-05) keys in order, then rise up the spindle and it becomes FG servo on.

CLV : Press the [TEST] (A8-5E) and [9] (A8-09) keys in order, then rise up the spindle and it becomes FG servo on.

⑧ Tracking open / close

1. Open tracking by pressing the [STEP FWD] (A8-54) key of the remote control unit in the play state.
2. Close tracking by pressing the [STEP REV] (A8-50) key of the remote control unit in the play state.

⑨ Slider servo on/off

1. Turn on the slider servo by pressing the [TEST] (A8-5E) and [CX] (A8-0E) keys in order.
2. Turn off the slider servo by pressing the [TEST] (A8-5E) and [TV/LDP] (A8-0F) keys in order.

⑩ Slider in / out

Slider in : In the tracking off state, press the [SCAN REV] (A8-11) key of the remote control unit.

Slider out : In the tracking off state, press the [SCAN FWD] (A8-10) key of the remote control unit.

⑪ Play (perform only the ID search and trace to the specified location)

Press the [TV/LDP] (A8-0F) key of the remote control unit from the stop state.

Perform only trace, video and audio output are nothing.

⑫ Screen display ON/OFF

1. Turn off the display by pressing the [AUDIO] (A8-1E) key of the remote control unit.
2. Turn on the display by pressing the [DISPLAY] (A8-43) key of the remote control unit.

A

⑬ Search**1. Search address input entry**

- It becomes the address input mode when pressing the [+10] (A8-1F) key. (Most significant digit of an address displays ">".)
- In this time, display the last address as the initial state.

2. Search address input

- Press the [0] to [9] (A8-00 to 09) keys of the remote control unit. In the DVD, set an address with hexadecimal.
- In the address input mode, turn to the hexadecimal input by pressing the [PROGRAM] (A8-4C) key (display a "*" mark), and [1] to [6] keys are each input as A to F.
- In this time, do not accept the [7],[8],[9] and [0] keys. Hexadecimal input and decimal input can switch with toggle.
- In case of CD, perform only the absolute time search.

B

3. Search execution

- Press the [CHP/TM] (A8-13) key of the remote control unit.
- After the search, perform only trace and video and audio outputs are nothing.

4. Release the Search address input

- Clear the address by pressing the [CLEAR] (A8-45) key. Release the address input mode when pressing the [CLEAR] key once again.

C

D

E

F

Display Specification of the Test Mode

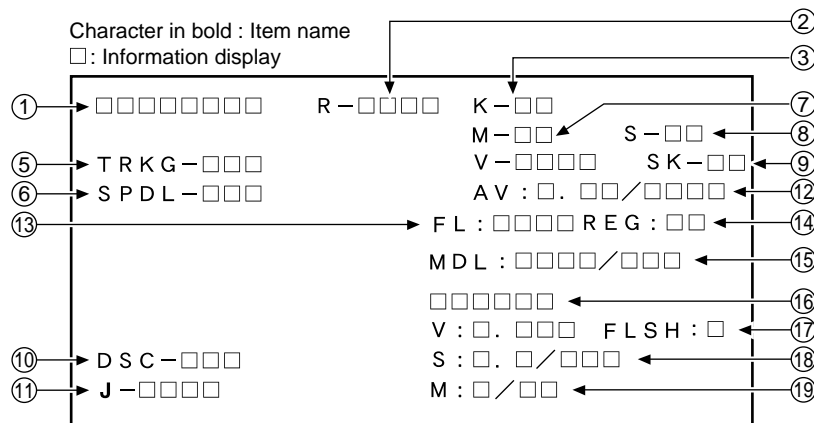

① Address indication

The address being traced is displayed in number.
(as for the DVD, indication of decimal number is possible.)
DVD : ID indication (hexadecimal number, 8 digits)
[*****]
CD : A-TIME (min. sec.) [0 0 0 0 *****]

② Code indication of remote control unit [R - *****]

In case of double code, display a 2nd code.

③ Main unit keycode indication [K - *****]

⑤ Tracking status [TRKG - *****]

Tracking on : [ON]
Tracking off : [OFF]

⑥ Spindle status [SPDL - *****]

[OFF], [A/B] (ACC/BRK), [CAV], [CLV]

⑦ Mechanism (loading) position value [M - *****]

Unknown : [01] or [41]
Open state : [04]
Close state : [08]
During opening : [12]
During closing : [22]

⑧ Slider position [S - *****]

CD TOC area : [IN]
CD active area : [CD]

⑨ Output video system [V - *****]

NTSC system : [NTSC]
PAL system : [PAL]
Automatic setting : [AUTO]

Scart terminal output [SK - *****]

(Display only the WY model which can do the output setting of scart terminal.)

VIDEO : [00]
S-VIDEO : [01]
RGB : [02]

⑩ Disc sensing [DSC - *****]

The type of discs loaded is displayed.
[DVD], [CD], [VCD], []

⑪ Jitter value [J - *****]

⑫ Version of the AV-1 chip / version of firmware [AV: ** / *****]

⑬ Version of the FL controller [FL: *****]

⑭ Region setting of the player [REG: *]

Setting value : [1] to [6]

⑮ Destination setting of the FL controller

[MDL: **** / *****]
Four characters in the front represent the type of model.
Three characters in the back represent the destination code.
J: /J, K: /KU, /KC, /R: /RAM/RL/RD, LB: /LB,
WY: /WY

⑯ Part number of the flash ROM

[*****]

⑰ Version of the flash ROM [V: *. *****]

Flash ROM size [FLSH = *]

⑱ Revision of the system controller [S: *. * / *****]

⑲ Revision of the DVD mechanism controller

[M: * / **]

■ Shortcut key Functional Specification

Only in the normal playback, the following setting can be by pressing the required key after having pressed the "ESC" key of the remote control unit. How to release: Press the "ESC" key. (function with indication)

| Command Contents | Conditions | Remote Control Key Name | Remote Control Code |
|----------------------------------------------------------------------|----------------------------|------------------------------------------------------------------------------------------------------|----------------------------------|
| Memory clear & region / revision indication | | CLEAR (LD remote control unit) | A8-45 |
| Average value measurement of DVD error rate | | 5 (LD remote control unit) | A8-05 |
| CD error rate measurement | | 5 (LD remote control unit) | A8-05 |
| Aspect: Pan scan | | 2 | AF-A2 |
| Aspect: Letter box | | 3 | AF-A3 |
| Aspect: Wide | | 4 | AF-A4 |
| Digital: PCM | | 5 | AF-A5 |
| Digital: AC-3/PCM | | 6 | AF-A6 |
| Virtual Dolby: VDD=OFF | Only correspondence model | 7 | AF-A7 |
| Virtual Dolby: VDD=ON | Only correspondence model | 8 | AF-A8 |
| Digital output ON | | REPEAT A | AF-E8 |
| Digital output OFF | | REPEAT B | AF-E4 |
| DTS Digital Out ON | | STEP FWD | AF-B7 |
| DTS Digital Out OFF | | STEP REV | AF-B8 |
| Scart terminal output: VIDEO | WY, Model to include scart | AUDIO | AF-BE |
| Scart terminal output: S-VIDEO | WY, Model to include scart | SUBTITLE | AF-36 |
| Scart terminal output: RGB | WY, Model to include scart | ANGLE | AF-B5 |
| Audio 5.1CH ON | Only correspondence model | KD_ENTER | AF-EF |
| FL indication of EDC / ID error | | CX (LD remote control unit) | A8-0E |
| ZOOM ON | Only correspondence model | ZOOM | AF-37 |
| ZOOM OFF | Only correspondence model | < X3 (LD remote control unit) | A8-59 |
| Service mode indication (error rate indication, etc.) | | CHP/TIM (LD remote control unit) | A8-13 |
| Model information indication | | CHAP (LD remote control unit) | A8-40 |
| Background color change | | +10 (LD remote control unit) | A8-1F |
| Audio last stage mute ON | | 9 | AF-A9 |
| Audio last stage mute OFF | | 0 | AF-A0 |
| Title search Input mode IN Title No. input Search execution | | SIDE A (LD remote control unit) Numbers (LD remote control unit) PLAY (LD remote control unit) | A8-4D A8-00 to A8-09 A8-17 |
| Region confirmation mode | | AUDIO (LD remote control unit) Numbers (LD remote control unit) | A8-1E A8-01 to A8-08 |

• Service mode indication

ID Address

Always display error rate. Exponential indication *.*e-* (with both DVD and CD)

EDC/ID/AV1 error history (ID Address, EDC/ID/AV1 Error, errors of past eight times)

Self-diagnostic function (when mechanism error occurred, display the mechanism error history)

• Error rate average value total (ESC +5)

Calculation number of times displays exponent from average value of eight times.

After the calculation result, display OK/NG. Tray is open in case of NG (with both DVD and CD)

DVD: OK with less than 8.0e-4 CD: OK with less than 7.6e-4

Note: Because an OK/NG judgment cannot be DVD with a static image mode as menu screen, confirm it by an animation.

• Model information indication contents (ESC+CHAP)

Display ⑫ to ⑰ in the test mode indication. However, Change the indication of S as B.E VERSION and it of M as F.E VERSION.

Refer to the "Specification of Model Information Display".

• Background color change

Change blue and green with toggle whenever pressing the key (the background color that green is using with SETUP NAVIGATOR).

• Region confirmation mode

Input region No. after pressing the ESC+AUDIO keys. When it is different from the setting, display and open the tray.

■ Specification of Model Information Display

• Display contents

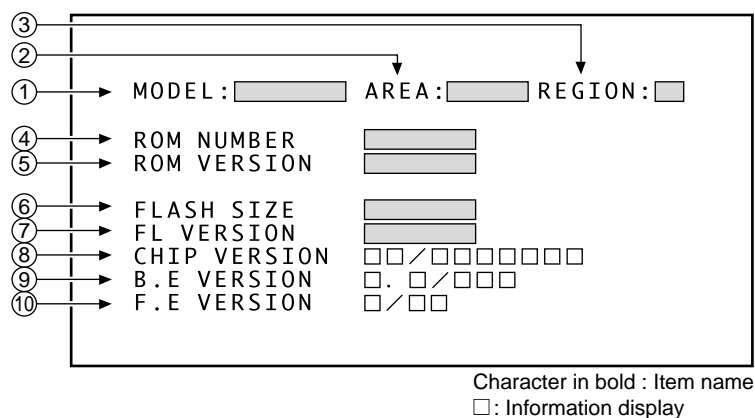

① **Model name**

Display it according to model information set from the FL controller.

② **Destination indication**

Display it according to model information set from the FL controller.

③ **Region No.**

④ **Part number**

⑤ **ROM version**

⑥ **Flash size**

⑦ **FL controller version**

⑧ **CHIP VERSION**

Version of ST CHIP

CUT ID / JTAG ID

↑ ↑
(two columns) (eight columns)

⑨ **B.E VERSION**

Version of BACK END (version of ST core software)

[].[] / [][][]
softwareVersion . softwareRevision / buildNumber

⑩ **F.E VERSION**

Version of FRONT END (version of mechanism controller CHIP software)

[] / [][]
MainVersion / SubVersion

Functional Specification of the Service Mode

• FL indication of EDC / ID error (short cut function)

Display it in FL with ESC+CX keys (LD remote control unit).
Indication is released with ESC key during indication.

FL indication contents

00 / 00 / 01 *

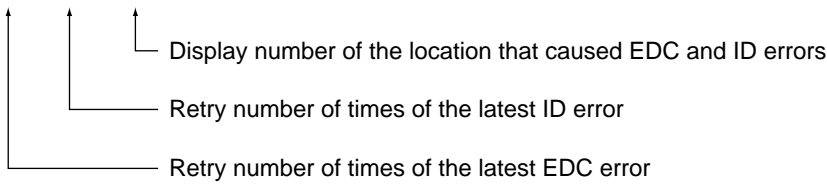

* mark: When even once causes AV1 error, lights.

• Service mode screen display

Display to the screen with ESC+CHP/TIM keys.
Release the indication with ESC key.

Indication contents

ID Address ①

Always indicate error rate ② and exponent indication

EDC/ID/AV1 error history (ID Address, EDC/ID/AV1 Error, past eight times) ③

Contents of AV1 error

BIT 0: EDC error, FEC I/F buffer overflow and not valid occur in the BE code (B.E error).

BIT 1: ID is different from the target in the BE code (B.E error).

BIT 2: There is error in the EDC data of 2 bytes which added to the FE (F.E error).

• Self-diagnostic function ④

Check that the F.E is normal or not.

FE OK : Abnormality is not found in the F.E.

FE Error : Abnormality is found in the F.E.

Indicate the mechanism error history by pressing the CHP/TIM key once again.

Change indication by pressing the CHP/TIM key with toggle afterwards.

Refer to the "Display of the Mechanism Error History".

Indication plan contents

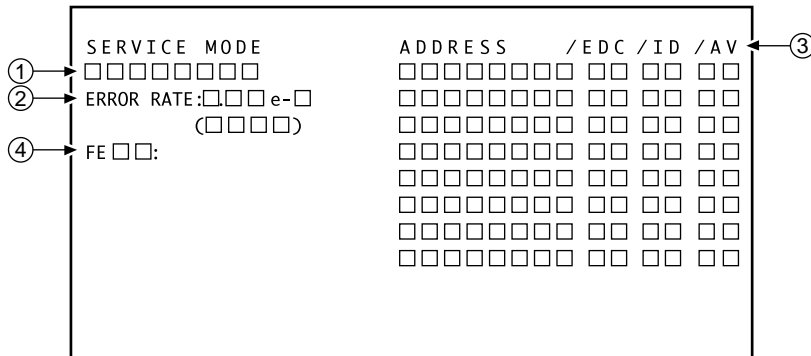

Character in bold : Item name
□ : Information display

7.1.2 DISPLAY OF THE MECHANISM ERROR HISTORY

When mechanism error (FE error) occurred, the mechanism error history of maximum past eight times is displayed by pressing the CHP/TIM key during service mode screen display.

Indication displayed in the screen upper part is new error.

• Indication contents

① Error code

Two characters in the front represent the Error Code and two characters in the back represent the Servo State. The detail is as follows.

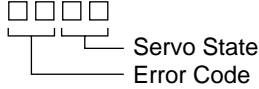

② Error occurrence time

Error indicates the time which occurred after system turned on the power supply.

* When time of new error is short, it becomes assumed power off once.

③ Error contents indication

Indicate the error contents which occurred with character.

Examples: When Error code is 0x13 (Focus lost timeout) and error state is 0x05 (Disc judge), "Focus lost timeout in Disc judge"

* Movement in the error occurrence: open the tray when SERVO STATE is Disc Judg, and others stop. However, error code is exception in the device error of 0xd*.

Indication contents

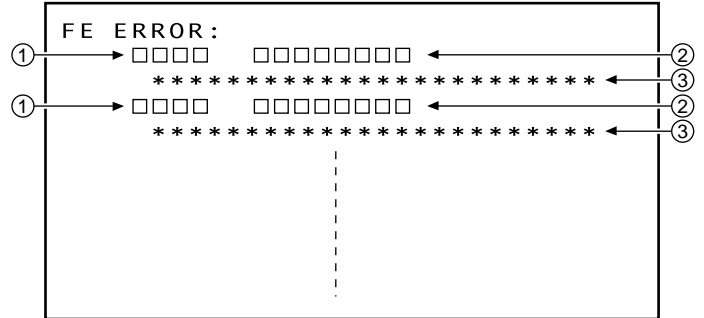

• Table of Error Code

| | | | |
|-------------------------------|------|---------------------------------|------|
| FOCUS ERROR | 0x0* | FOCUS TIMEOUT | 0x1* |
| Focus on error | 0x01 | Focus on timeout | 0x11 |
| Focus off error | 0x02 | Focus off timeout | 0x12 |
| Focus lost error | 0x03 | Focus lost timeout | 0x13 |
| Focus balance adjust error | 0x04 | Focus balance adjust timeout | 0x14 |
| Focus gain adjust error | 0x05 | Focus gain adjust timeout | 0x15 |
| Focus sweep error | 0x06 | Focus sweep timeout | 0x16 |
| Focus reflection error | 0x07 | Focus reflection timeout | 0x17 |
| TRACKING ERROR | 0x2* | TRACKING TIMEOUT | 0x3* |
| Tracking on error | 0x21 | Tracking on timeout | 0x31 |
| Tracking off error | 0x22 | Tracking off timeout | 0x32 |
| Tracking lost error | 0x23 | Tracking lost timeout | 0x33 |
| Tracking balance adjust error | 0x24 | Tracking balance adjust timeout | 0x34 |
| Tracking gain adjust error | 0x25 | Tracking gain adjust timeout | 0x35 |
| Tracking jump error | 0x26 | Tracking jump timeout | 0x36 |
| STEPPING ERROR | 0x4* | STEPPING TIMEOUT | 0x5* |
| Stepping on error | 0x41 | Stepping on timeout | 0x51 |
| Stepping off error | 0x42 | Stepping off timeout | 0x52 |
| Stepping lost error | 0x43 | Stepping lost timeout | 0x53 |
| Stepping move error | 0x44 | Stepping move timeout | 0x54 |
| SPINDLE ERROR | 0x6* | SPINDLE TIMEOUT | 0x7* |
| Spindle on error | 0x61 | Spindle on timeout | 0x71 |
| Spindle off error | 0x62 | Spindle off timeout | 0x72 |
| Spindle lost error | 0x63 | Spindle lost timeout | 0x73 |
| Spindle CAV error | 0x64 | Spindle CAV timeout | 0x74 |
| Spindle CLV error | 0x65 | Spindle CLV timeout | 0x75 |
| ACQUISITION ERROR | 0x8* | ACQUISITION TIMEOUT | 0x9* |
| PLL lost error | 0x83 | PLL lost timeout | 0x93 |
| DECODER ERROR | 0xa* | DECODER TIMEOUT | 0xb* |
| ID lost error | 0xa3 | ID lost timeout | 0xb3 |
| DEVICE ERROR | 0xd* | FAIL SAFE | 0xe* |
| SRAM error | 0xd1 | unexpected error | 0xe1 |

• Table of Servo State

| | |
|------|------------------------|
| 0x00 | Reset |
| 0x01 | Stop (inside position) |
| 0x02 | Stop (any position) |
| 0x03 | Braking for stop |
| 0x04 | New disc |
| 0x05 | Disc judge |
| 0x06 | Reserved 1 |
| 0x07 | Playing |
| 0x08 | Start up |
| 0x09 | Seeking |
| 0x0A | Pausing |
| 0x0B | Reading BCA |
| 0x0C | Reserved 2 |
| 0x0D | |
| 0x0E | |
| 0x0F | |

ERROR CODE TABLE

| Error Name | No. | Causes | Check Item | Possibility of Trouble | Remarks |
|----------------------------------|--------|------------------------------------------------------|----------------------------------------------------------------------------------------------------------------------------------------|----------------------------------------------------|---------|
| FOCUS ERROR (0 x 0*) | | | | | |
| Focus on error | 0 x 01 | Focus on could not be completed | Are not there a dirt or a scratch in the Disc? Does LD become weak? Does the lens move up and down? | 1. Pickup 2. Driver 3. L6315 (Front End IC) | |
| Focus off error | 0 x 02 | Focus off could not be completed | Unknown | | |
| Focus lost error | 0 x 03 | Focus servo is lost | Are not there a dirt or a scratch in the Disc? Does LD become weak? | 1. Pickup | |
| Focus balance adjust error | 0 x 04 | AFB on could not be completed | | | |
| Focus gain adjust error | 0 x 05 | Focus AGC could not be completed | | | |
| Focus sweep error | 0 x 06 | | | | |
| Focus reflection error | 0 x 07 | Dimensions of S curve did not reach to the aim value | Does LD become weak? | 1. Pickup | |
| FOCUS TIMEOUT (0 x 1*) | | | | | |
| Focus on timeout | 0 x 11 | Did timeout at focus on | Are not there a dirt or a scratch in the Disc? Does LD become weak? Does the lens move up and down? | 1. Pickup 2. Driver 3. L6315 (Front End IC) | |
| Focus off timeout | 0 x 12 | Did timeout at focus off | | | |
| Focus lost timeout | 0 x 13 | Did timeout at focus backup | | | |
| Focus balance adjust timeout | 0 x 14 | Did timeout at AFB | | | |
| Focus gain adjust timeout | 0 x 15 | Did timeout at AGC | | | |
| Focus sweep timeout | 0 x 16 | | | | |
| TRACKING ERROR (0 x 2*) | | | | | |
| Tracking on error | 0 x 21 | Tracking on could not be completed | | 1. Pickup 2. Driver 3. L6315 (Front End IC) | |
| Tracking off error | 0 x 22 | Tracking off could not be completed | | | |
| Tracking lost error | 0 x 23 | Tracking servo is lost | | 1. Pickup | |
| Tracking balance adjust error | 0 x 24 | ATB could not be completed | | 1. Pickup | |
| Tracking gain adjust error | 0 x 25 | AGC could not be completed | | 1. Pickup | |
| Tracking jump error | 0 x 26 | Tracking jump could not be completed | | | |
| TRACKING TIMEOUT (0 x 3*) | | | | | |
| Tracking on timeout | 0 x 31 | Did timeout at tracking on | Are not there a dirt or a scratch in the Disc? | 1. Pickup 2. Driver 3. L6315 (Front End IC) | |
| Tracking off timeout | 0 x 32 | Did timeout at tracking off | | | |
| Tracking lost timeout | 0 x 33 | Did timeout at tracking backup | Are not there a dirt or a scratch in the Disc? | 1. Pickup | |
| Tracking balance adjust timeout | 0 x 34 | Did timeout at ATB | | 1. Pickup | |
| Tracking gain adjust timeout | 0 x 35 | Did timeout at AGC | | 1. Pickup | |
| Tracking jump timeout | 0 x 36 | Did timeout at tracking jump | | | |
| STEPPING ERROR (0 x 4*) | | | | | |
| Stepping on error | 0 x 41 | Stepping on could not be completed | | 1. Pickup 2. Driver 3. L6315 (Front End IC) | |
| Stepping off error | 0 x 42 | Stepping off could not be completed | | | |
| Stepping lost error | 0 x 43 | Stepping servo is lost | | | |
| Stepping move error | 0 x 44 | Stepping could not move | Do move to inner and outer periphery of the stepping in the test mode? Do indicate "S-04" at the most inner periphery of the stepping? | 1. Stepping motor 2. Inside switch 3. Driver | |
| STEPPING TIMEOUT (0 x 5*) | | | | | |
| Stepping on timeout | 0 x 51 | Did timeout at stepping on | | 1. Pickup 2. Driver 3. L6315 (Front End IC) | |
| Stepping off timeout | 0 x 52 | Did timeout at stepping off | | | |
| Stepping lost timeout | 0 x 53 | Did timeout at stepping backup | | | |
| Stepping move timeout | 0 x 54 | Did timeout at stepping movement | Do move to inner and outer periphery of the stepping in the test mode? Do indicate "S-04" at the most inner periphery of the stepping? | 1. Stepping motor 2. Inside switch 3. Driver | |

| Error Name | No. | Causes | Check Item | Possibility of Trouble | Remarks |
|-------------------------------------|--------|------------------------------------|----------------------------------------------------------------------------------------|------------------------------------------------------------------|---------|
| SPINDLE ERROR (0 x 6*) | | | | | |
| Spindle on error | 0 x 61 | Spindle on could not be completed | | | |
| Spindle off error | 0 x 62 | Spindle off could not be completed | | | |
| Spindle lost error | 0 x 63 | Spindle lost control | | | |
| Spindle CAV error | 0 x 64 | CAV on could not be completed | | | |
| Spindle CLV error | 0 x 65 | CLV on could not be completed | | | |
| SPINDLE TIMEOUT (0 x 7*) | | | | | |
| Spindle on timeout | 0 x 71 | Did timeout at spindle on | | | |
| Spindle off timeout | 0 x 72 | Did timeout at spindle stop | | | |
| Spindle lost timeout | 0 x 73 | Did timeout at spindle backup | Are not there a dirt or a scratch in the Disc? Is FG output from the driver? | 1. Spindle motor 2. Spindle driver | |
| Spindle CAV timeout | 0 x 74 | Did timeout at CAV on | Is spindle rotating? Is FG output from the driver? Is the PDM output from L6315? | 1. Spindle motor 2. Spindle driver 3. L6315 (Front End IC) | |
| Spindle CLV timeout | 0 x 75 | Did timeout at CLV on | | | |
| ACQUISITION ERROR (0 x 8*) | | | | | |
| PLL lost error | 0 x 83 | PLL is lost | Are not there a dirt or a scratch in the Disc? | 1. Pickup 2. L6315 (Front End IC) | |
| ACQUISITION TIMEOUT (0 x 9*) | | | | | |
| PLL lost timeout | 0 x 93 | Did timeout at PLL backup | Are not there a dirt or a scratch in the Disc? | 1. Pickup 2. L6315 (Front End IC) | |
| DECODER ERROR (0 x a*) | | | | | |
| ID lost error | 0 x a3 | ID is not readable | Are not there a dirt or a scratch in the Disc? | 1. Pickup 2. L6315 (Front End IC) | |
| DECODER TIMEOUT (0 x b*) | | | | | |
| ID lost timeout | 0xb3 | Did timeout at ID backup | Are not there a dirt or a scratch in the Disc? | 1. Pickup 2. L6315 (Front End IC) | |
| DEVICE ERROR (0 x d*) | | | | | |
| SRAM error | 0 x d1 | Cannot access SRAM | Power supply of SRAM Is not bus line short-circuiting? | 1. SRAM 2. L6315 (Front End IC) 3. L6315-SRAM bus line | |
| FAILSAFE (0 x e*) | | | | | |
| Unexpected error | 0 x e1 | Unexpected error | | 1. software runaway 3. Software bug | |

7.1.3 TEST POINT LOCATION & WAVEFORMS

SIDE A

B FJMB ASSY

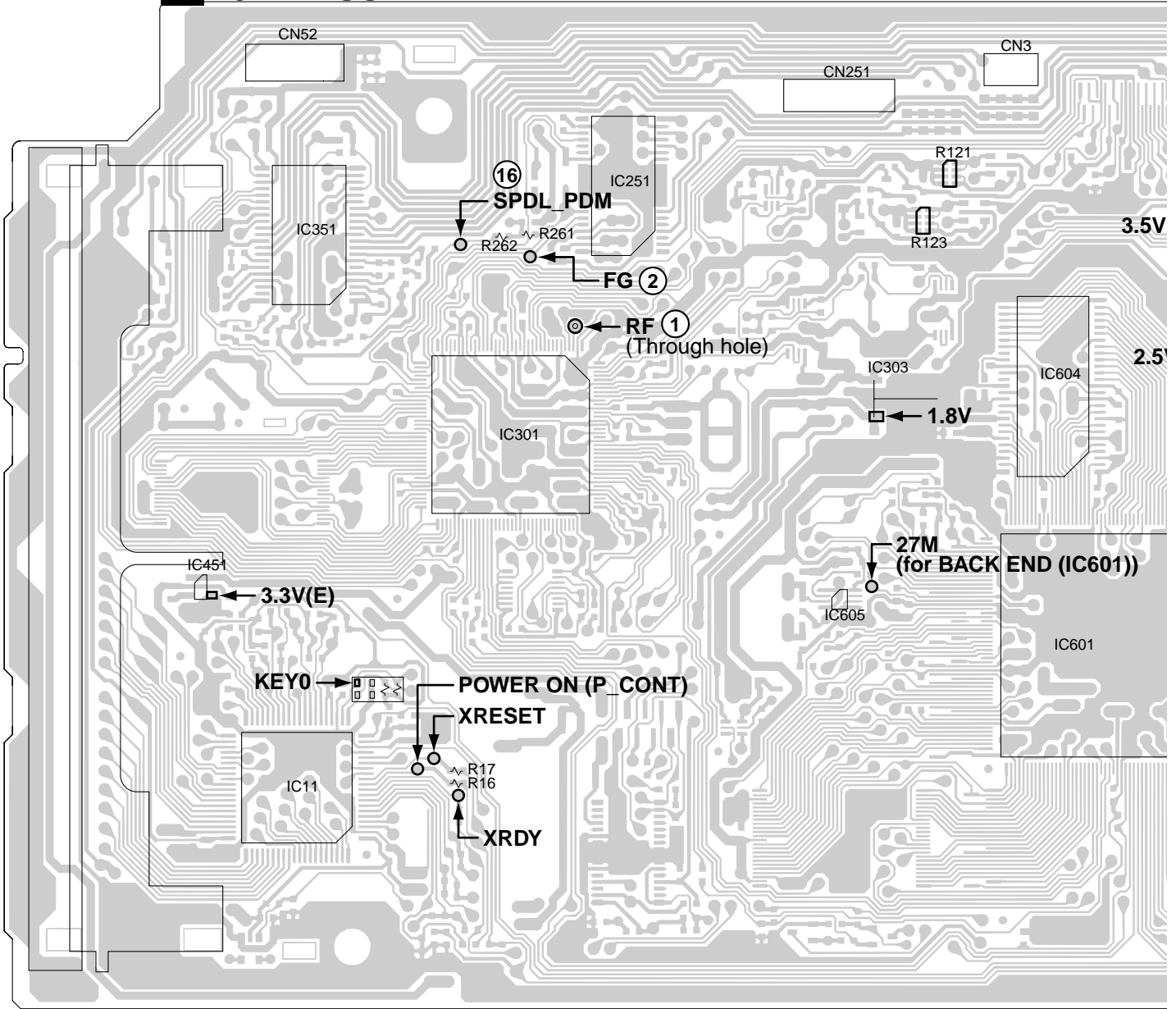

WAVEFORMS

Measurement condition : No. 1, 2, 9, 13 and 14 : reference A1 (DVD), T2-chp 19, Color-bar
No. 3 to 8 : reference A1 (DVD), T2-chp 1

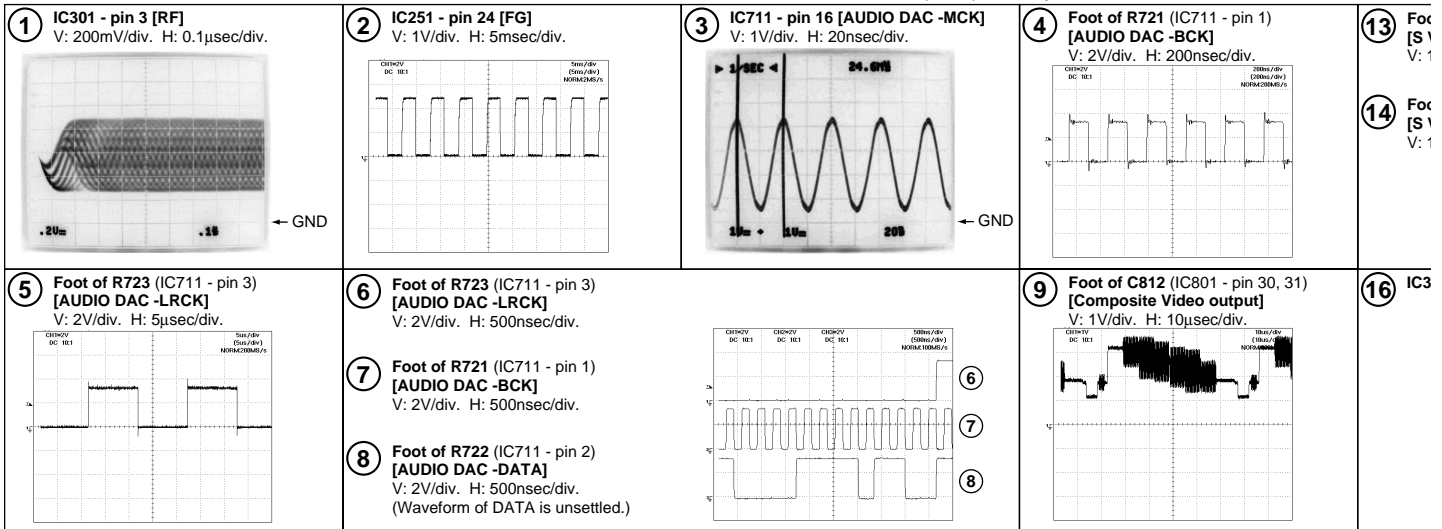

SIDE A

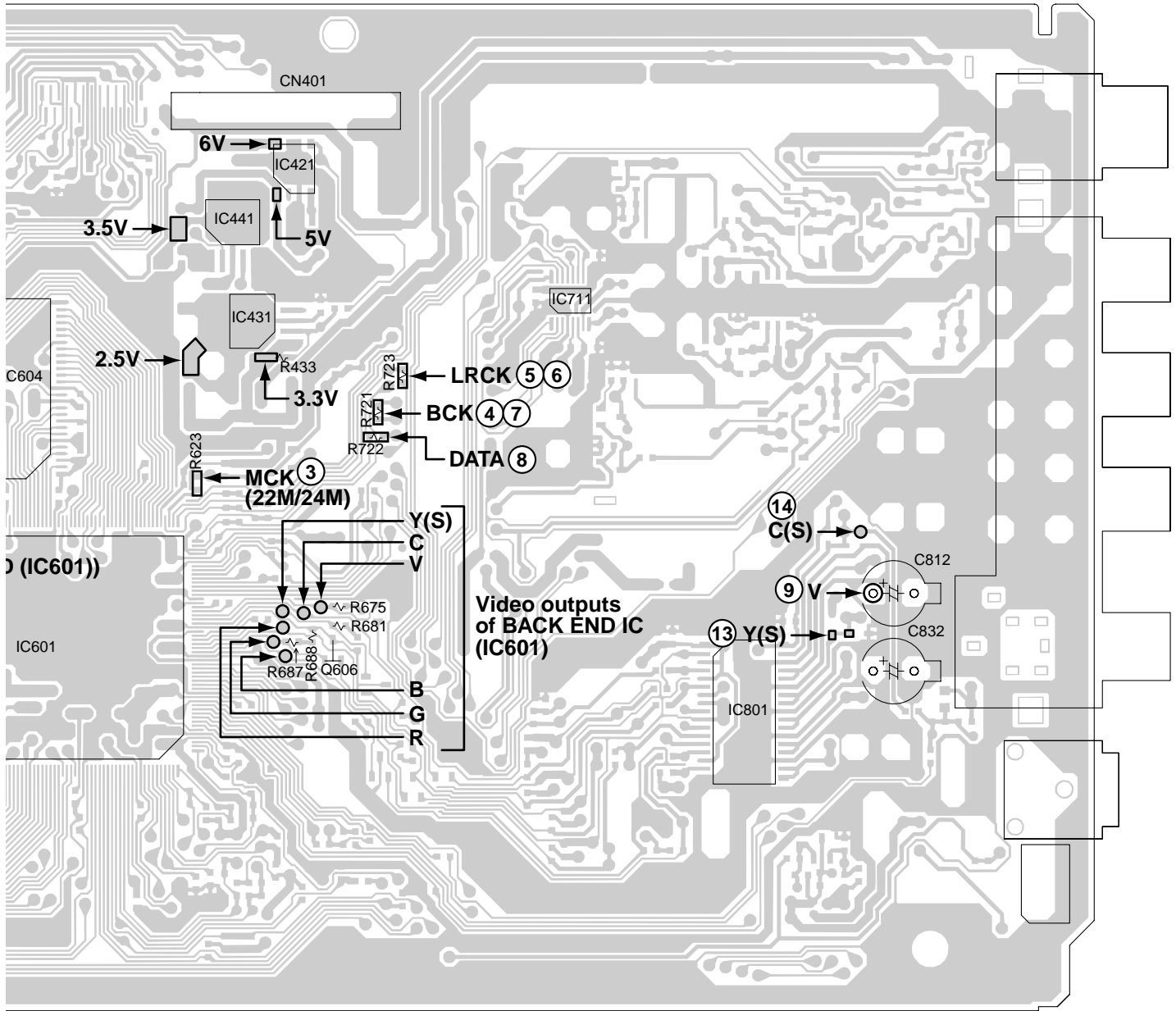

13 Foot of C832 (IC801 - pin 27, 28)
 [S Video output -Y]
 V: 1V/div. H: 10µsec/div.

14 Foot of C822 (IC801 - pin 33)
 [S Video output -C]
 V: 1V/div. H: 10µsec/div.

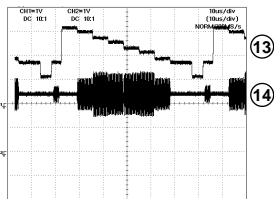

31) 16 IC301 - pin 42 [SPDL_PDM]

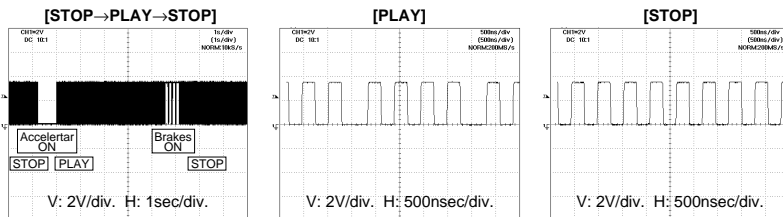

SIDE B

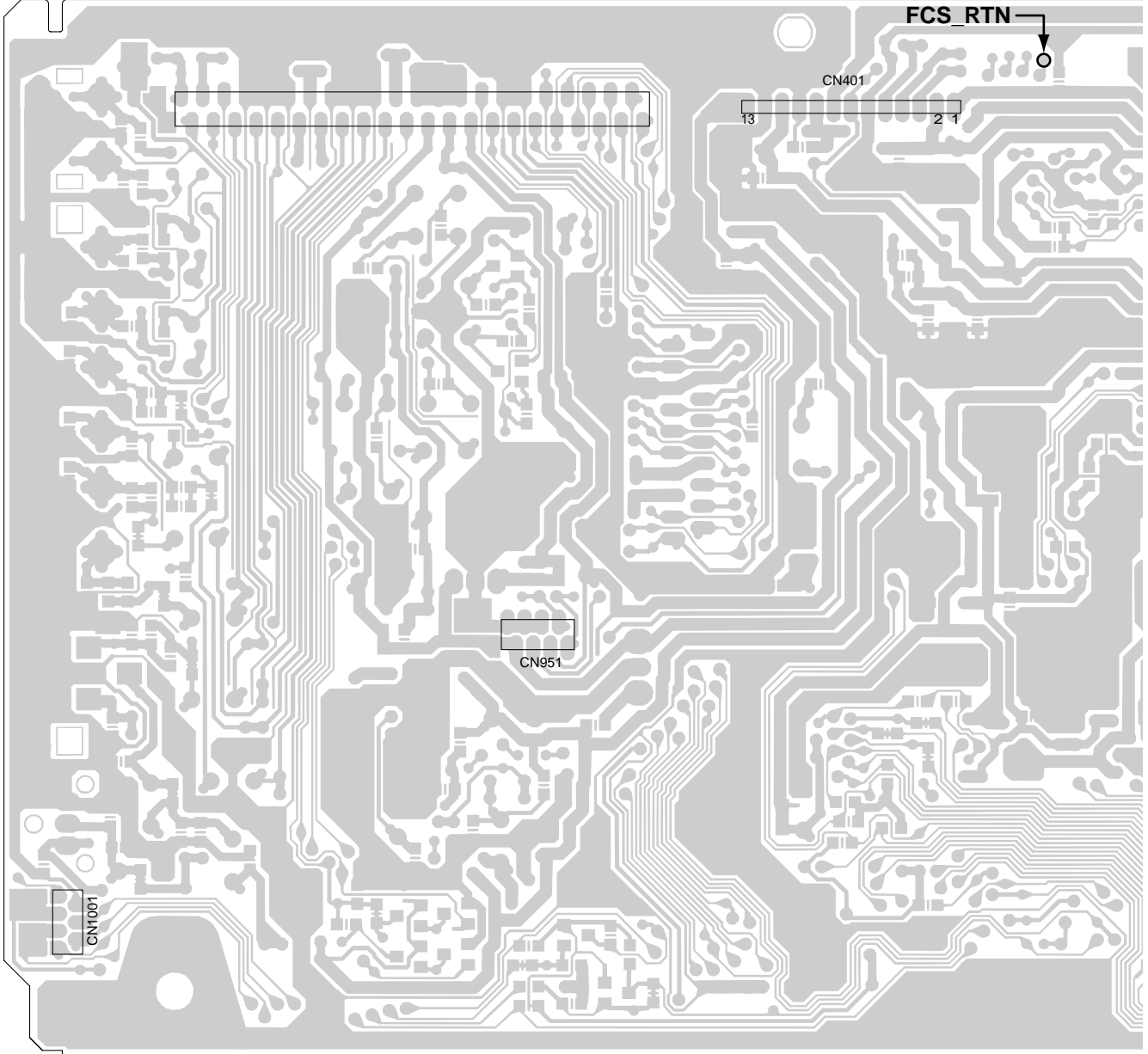

A

B

C

D

E

F

W

①5 IC6
V: 1

B FJMB ASSY

SIDE B

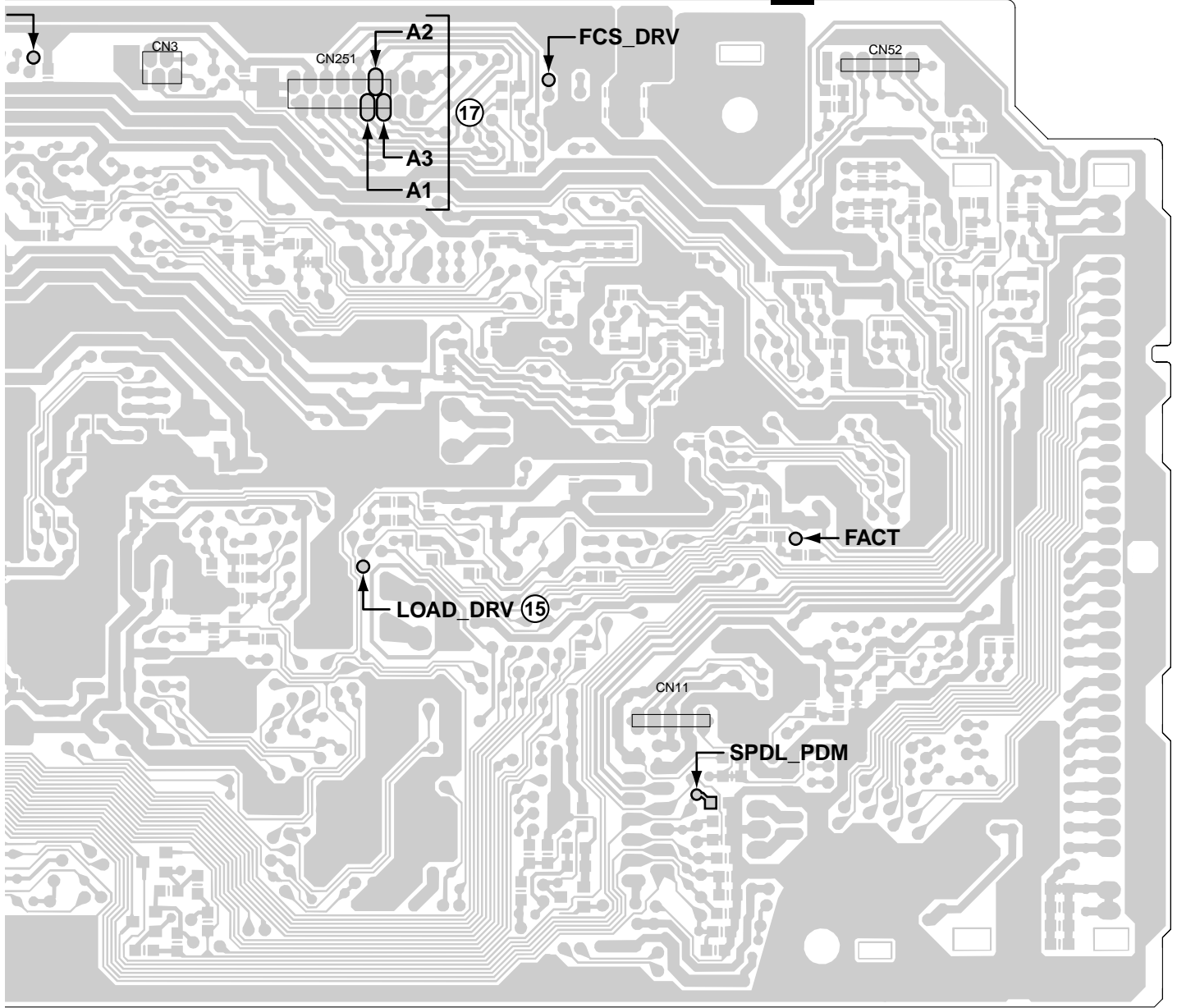

WAVEFORMS

(15) IC601 - pin 116 [LOAD_DRV]
 V: 1V/div. H: 5µsec/div.

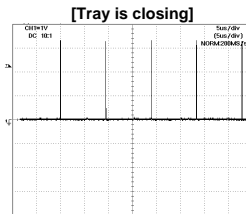
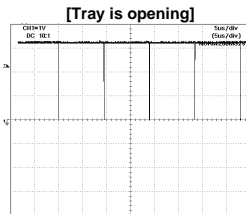
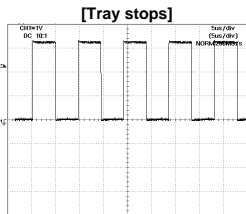

(17) CN251 - pin 12, 11, 10
 (IC251 - pin 2, 4, 7)
 [Spindle driver -A3, A2, A1]

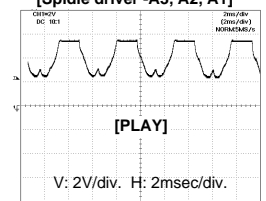

SIDE A

G SCRIB ASSY

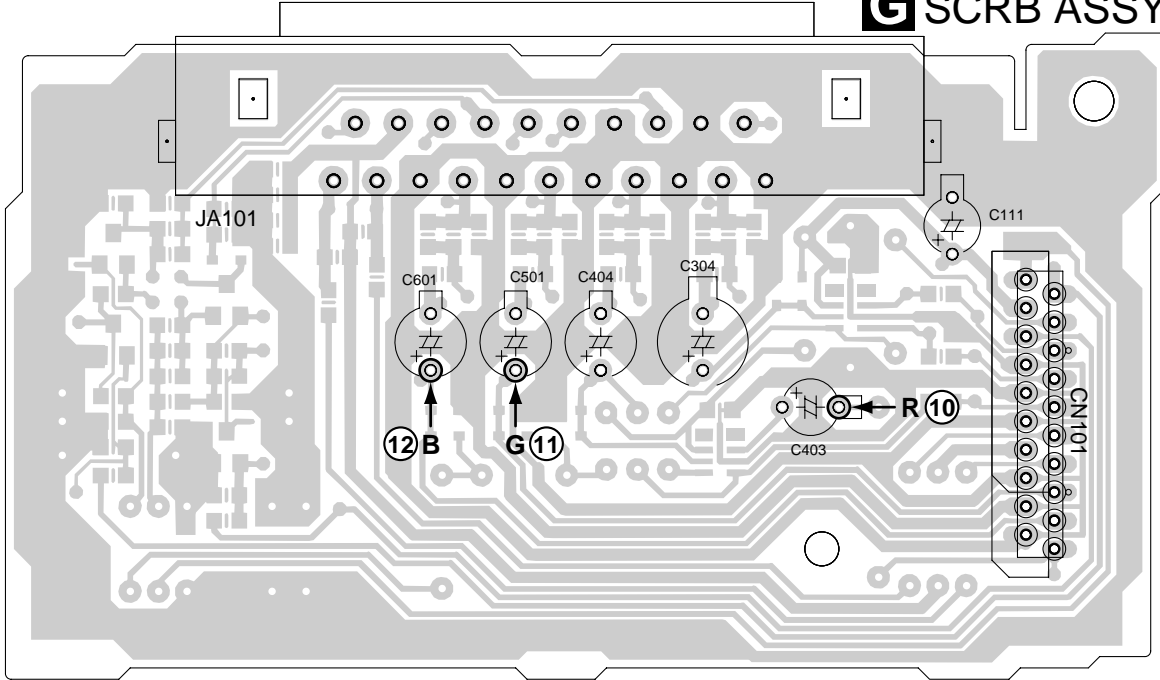

WAVEFORMS

Measurement condition : reference A1 (DVD), T2-chp 19, Color-bar

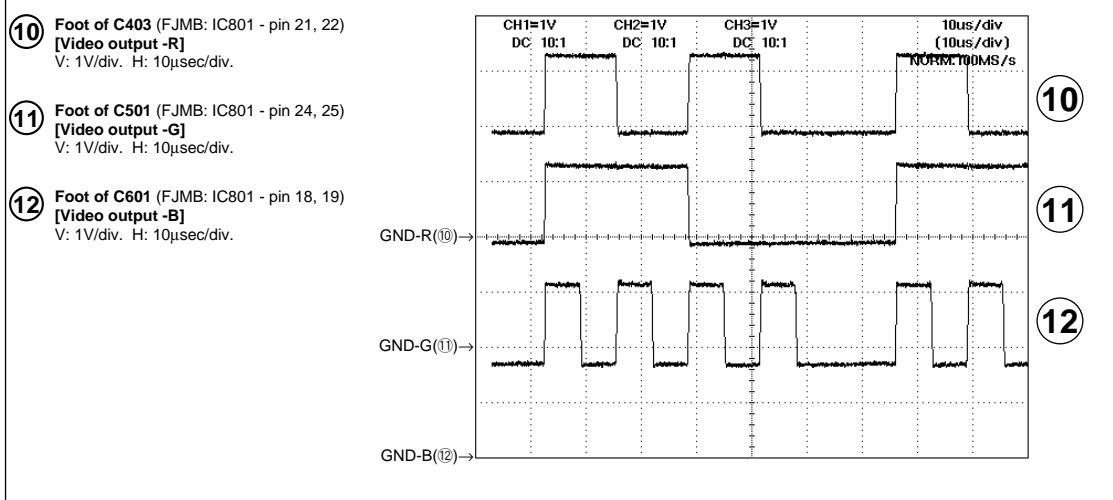

7.1.4 TROUBLE SHOOTING

At first confirm error history. (Refer to "7.1.2 DISPLAY OF THE MECHANISM ERROR HISTORY")

When a history was not displayed, refer to this list.

| No. | Symptoms | Diagnosis contents | Defectiveness assumption points |
|-----|---------------------------------------------------------------------------------------|----------------------------------------------------------------------------------------------------------------------------------------------------------------------------------------------------------------------------------------------------------------------------------|------------------------------------------------------------------------------------------------------------|
| 1 | Cannot power on | Check each voltage of POWER SUPPLY UNIT (E+4V, -28V and FLDC output) | POWER SUPPLY UNIT |
| | | Are not there short-circuit and open-circuit between output connector of POWER SUPPLY UNIT and CN401 of FJMB? | Connector / wire rod |
| | | Check that voltage of IC451-pin 4 is 3.3V. | 3.3V regulator |
| | | FJMB IC11-22pin: 0V, is it 3.3V when I pushed a POWER key when I do not push it? | tact-switchies (in case of only a key of a product, NG) |
| | | Does FJMB IC11-pin 17 (SEL IR) receive a message of a signal between 0V - 3.3V when I pushed a wireless remote controller key? | Wireless remote controller receiver light part (in case of only a key of a wireless remote controller, NG) |
| 2 | An opening screen is not displayed by a monitor (FL turns on. A mecha does not work.) | Are IC11-pin 12 (XRESET) and IC11-pin 11 (POWER ON) "H" level together? | FL control u-com (IC11) |
| | | <ul style="list-style-type: none"> Check each voltage of POWER SUPPLY UNIT(E+6V and SW+3.3V) As for P-CONT of POWER SUPPLY UNITY, are there around 3V? | POWER SUPPLY UNIT |
| | | IC441-3pin: 3.5V, IC431-pin 3: 2.5V, IC303-pin 3: 1.8V Are these each output? | Each regulator |
| | | Is there number of vibrations in a standard whether crystal resonator does oscillation? | Crystal resonator (27MHz, 20MHz) |
| | | Refer to contents of a FE error displayed by FL display. (SRAM defectiveness, I2C communication line defectiveness, other) | L6315 (FRONT END IC: IC301) |
| | | <ul style="list-style-type: none"> Is a signal input into IC603-pin 26 (CE3) just after power on? [L ↔ H] → Communication with flash ROM Is a signal input into IC604 pin-16 (SMIWE), 19pin (SMICS0), 38pin (SMICLK)? [L ↔ H] → Communication with SDRAM | STI5519 (BACK END IC: IC601) |
| | | Is a signal output by IC603-pin 28 (CPU _ OE) just after power on? [L ↔ H] | Flash ROM (IC603) |
| | | Is a signal input into IC11-pin 16 (FP _ ACK)? [L ↔ H] → Communication with FL control u-com | STI5519 (BACK END IC: IC601) |
| | | Is a signal output by IC11-pin 10 (XRDY)? (around 0-3V, L ↔ H) | FL control u-com (IC11) |
| | | Is a signal output by IC11-pin 9, 8, 7? (around 0-3V) | FL control u-com -BACK END communication line |
| 3 | An opening screen is not displayed by a monitor (FL turns on. A mecha works.) | Check BACK END IC and video signal path between video-out (cf. block diagram) | The video circuit after BACK END |
| 4 | Cannot open a tray (An opening screen is displayed by a monitor) | Does voltage of CN52-pin 3, 5 change normally? pin 3 (XCLOSE): It is "H" level by the state that has finished doing CLOSE. pin 5 (OPEN): It is "H" level by the state that has finished doing OPEN. | Tray-SW |
| | | Does LOAD_DRV signal come? | STI5519 (BACK END IC: IC601) |
| | | Is a signal output by IC351-pin 14, 15 (CN52-1, 2pin)? (pin 15: It is about 6V during tray opening, It is about 0V during tray closing) (pin 14: It is about 0V during tray opening, It is about 6V during tray closing) | FTS Driver IC (IC351) |
| | | Are not there wire rod coming out, damage in CN3, CN52? | Connector / wire rod |
| | | When the voltage of a CN251-pin 1 overwhelmed an inside switch, does it change? | Inside switch |

| No. | Symptoms | Diagnosis contents | Defectiveness assumption points |
|-----|---------------------------------------------------------------------|-----------------------------------------------------------------------------------------------------------------------------------------------------------------|-----------------------------------------------|
| 5 | Cannot playback (Focus does not inn) | Is a signal output by IC351-pin 9, 10? | FTS Driver IC (IC351) |
| | | Does 650 LD emit light? Does a pickup lens do up /down? Does not an actuator spring turn? | PICKUP |
| | | Are not resin part damage, a shaft missing? Are not there falling off of turn table, lean abnormality? | Mechanism Assy |
| | | Is not there wire rod coming out of CN151? Is not PU flexible cable damaged? | Flexible cable / connector |
| | | Is signal output by IC301-pin 123 (FACT)? (Device control of around 500mV is output usually. It is \pm around 100mV swing by focus up / down.) | L6315 (FRONT END IC: IC301) |
| 6 | Cannot playback (Spindle does not turn) | Is a signal output by IC251-pin 2(A3), 4(A2), 7(A1)? It is fixed, and is not there IC251-pin 18 HIGH whether it is fixed, and there is not IC251-pin 23 LOW? | Spindle Driver IC (IC251) |
| | | Are not there part falling off, alien substance adhesion in spindle motor part? | Mechanism Assy (Spindle motor) |
| | | Are not there wire rod coming out, damage in CN251? | Flexible cable / connector |
| | | Is signal output by IC301-pin 123 (SPDL_PDM)? | L6315 (FRONT END IC: IC301) |
| 7 | Cannot playback (Playback stops) | Does not 650nLD deteriorate? If there is the both ends voltage of R121 more than 0.7V, 650nLD deteriorates surely. | 650nLD deteriorates. (Cannot playback DVD) |
| | | Does not 780nLD deteriorate? If there is the both ends voltage of R123 more than 1.2V, 780nLD deteriorates surely. | 780nLD deteriorates. (Cannot playback CD) |
| | | Is not there abnormality in FG waveform? | FG output: Spindle Driver IC (IC251) |
| | | Are not there wound and a dirt on the disc? | Disc |
| 8 | Picture disturbance during playback (block noise, freeze, other) | Are not there wound and a dirt on the disc? Do not you set a disc of standard outside? | Disc |
| 9 | Audio is not output (Picture is normal) | Check the waveform (BCK, LRCK, MCLK, DATA). | ST15519 (BACK END IC: IC601) |
| | | Is signal output by IC711-pin 7, 8? | AUDIO DAC IC (IC711) |

7.1.5 SEQUENCE AFTER THE POWER ON

Flow chart from power on to the picture output

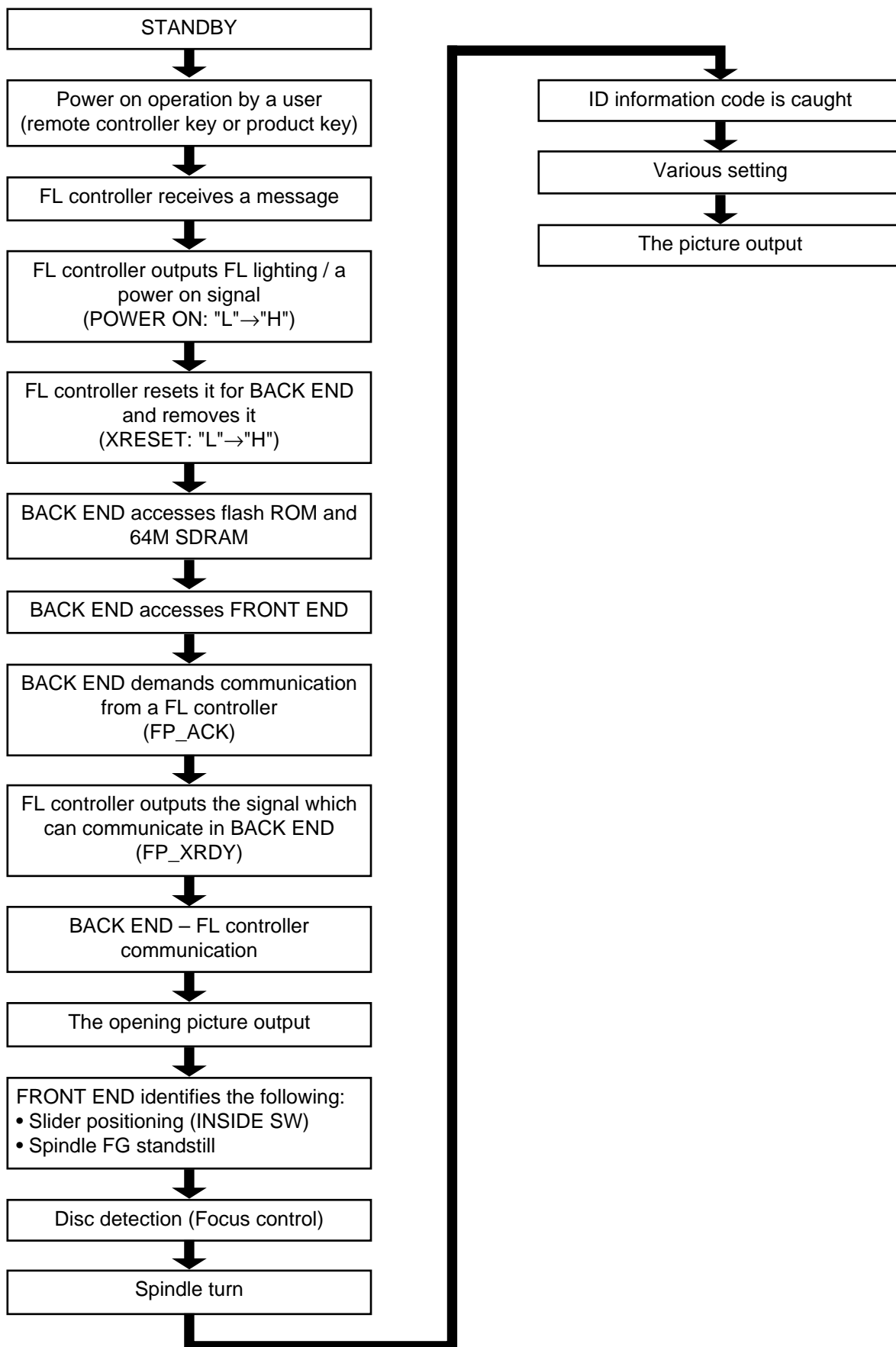

7.1.6 DISASSEMBLY

DIAGNOSIS OF FJMB ASSY

1 Bonnet and Tray Panel

- ① Remove the Bonnet (Screws × 6)
- ② Power ON
- ③ Tray open (▲)
- ④ Remove the Tray Panel
- ⑤ Tray close (▲)
- ⑥ Pull out the Power Cable from the outlet.

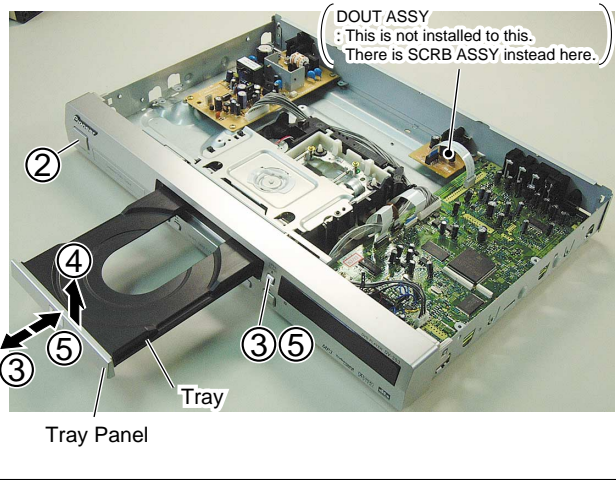

How to Open the Tray by Manual Operating

In the reverse state, pass a small screwdriver through a slit and slide a protruding portion of the Drive Gear of the Loading Mechanism Assy to the direction of arrow.
If the Tray moved toward the front about 2 or 3 cm, pull out the Tray by hands.

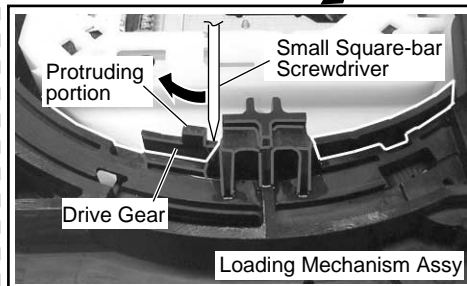
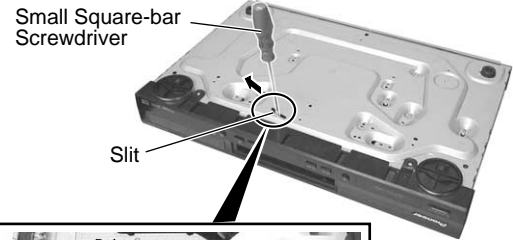

2 Front Panel Assy

- ① Unclamp the wire.
- ② Disconnect the wiring.
- ③ Unhook (×6)
- ④ Remove the Front Panel.

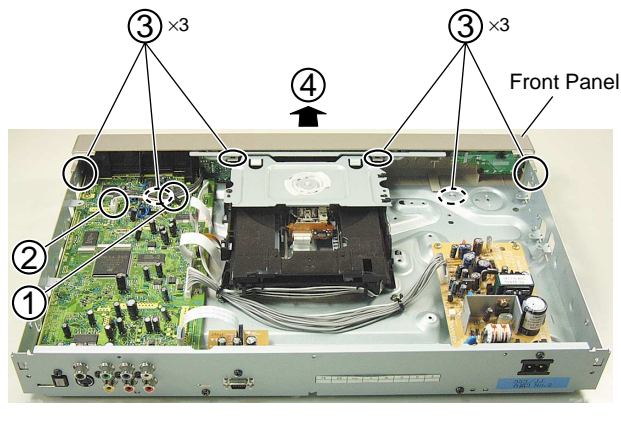

3 Diagnosis of FJMB Assy

- ① Unscrew the Rear Panel and remove the Rear Panel (Screw ×8).
- ② Unscrew the FJMB Assy (Screw ×4).

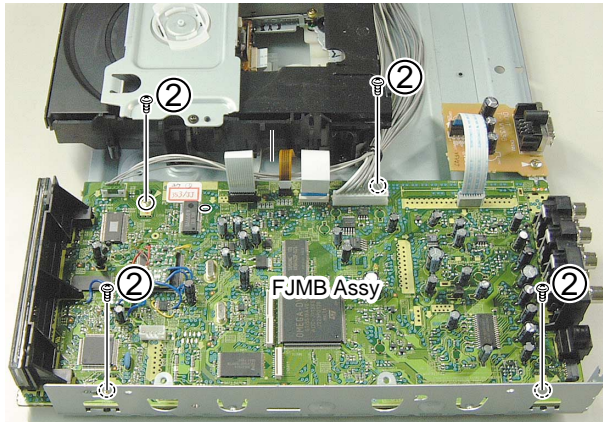

- ③ Stand the FJMB Assy.
- ④ Set the Front Panel Assy (one connector) to the FJMB Assy.

from Front Panel Assy

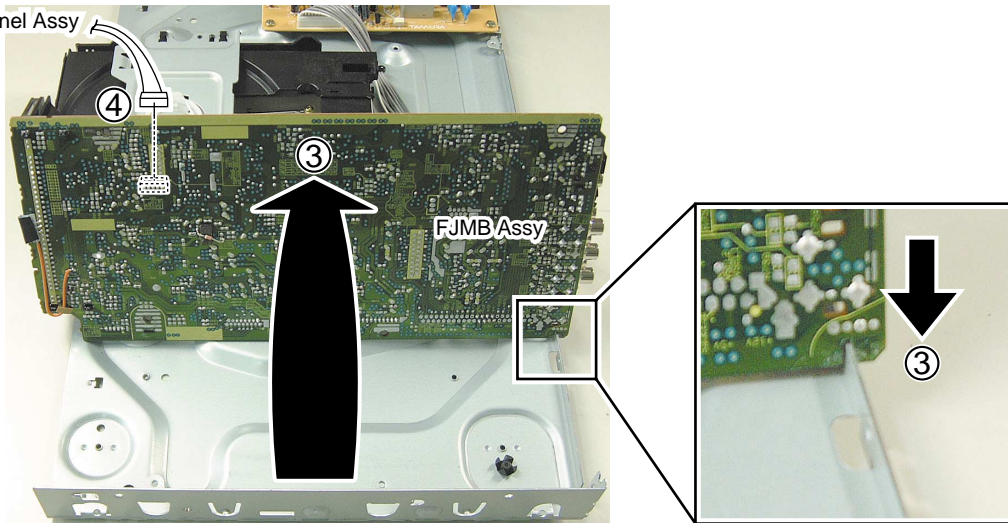

- ⑤ Put the Power Cable in the outlet.
- ⑥ Power ON
- ⑦ Set the Test Disc.
- ⑧ Playback with a test disc, and diagnose the FJMB Assy.

A

Disassembly of the Traverse Mechanism Assy and the Pickup Assy

- ① Remove the Bonnet and the Tray Panel.
- ② Unclamp the wire.
- ③ Turn the Short SW to Short side.
- ④ Disconnect the wiring (x4).
- ⑤ Unscrew the Loading Mechanism Assy (Screws x4).
- ⑥ Unhook (x2).
- ⑦ Remove the Loading Mechanism Assy.

B

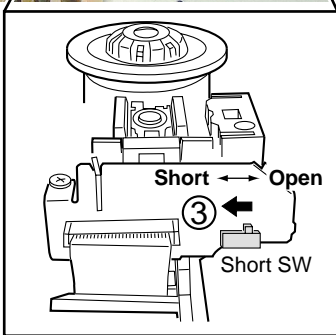
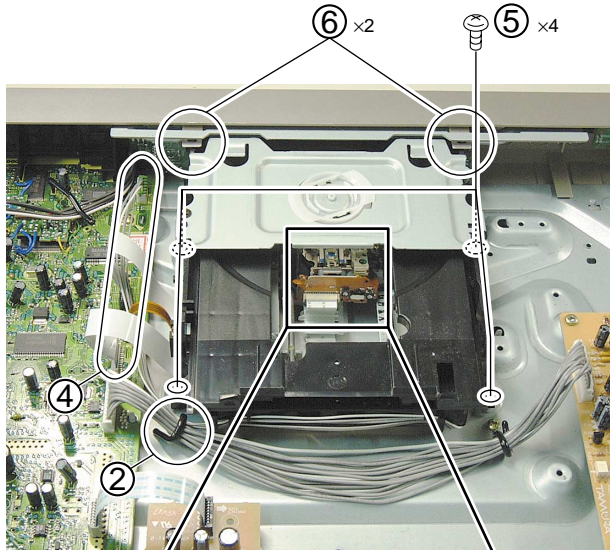

C

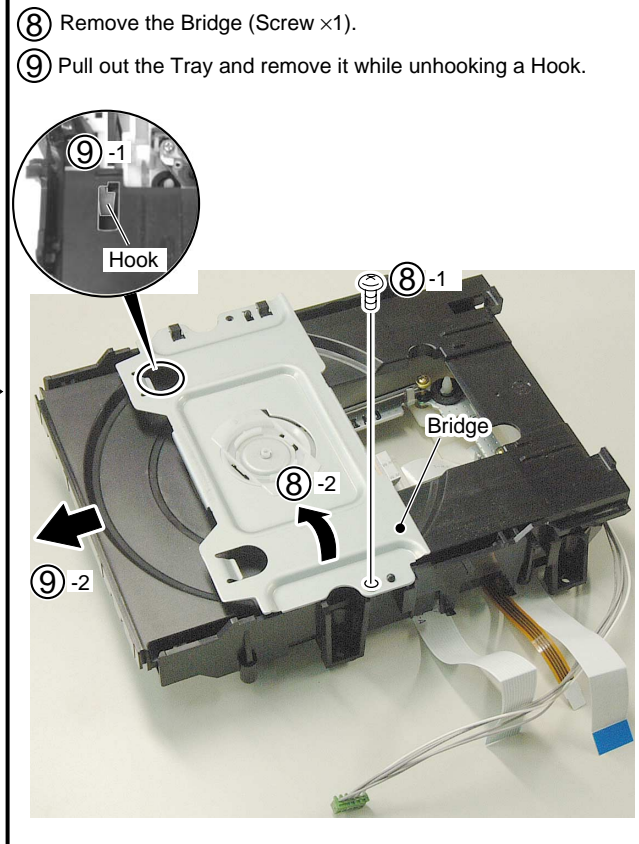

D

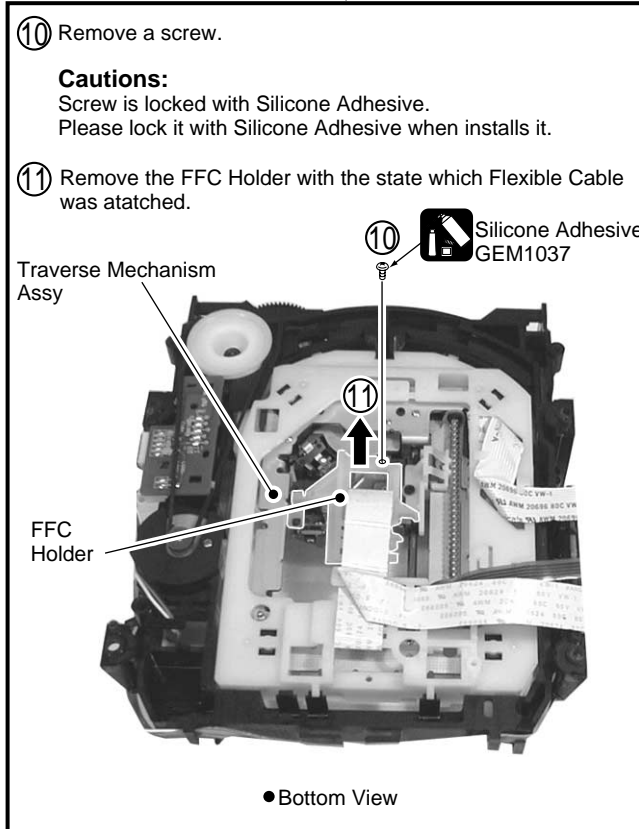

E

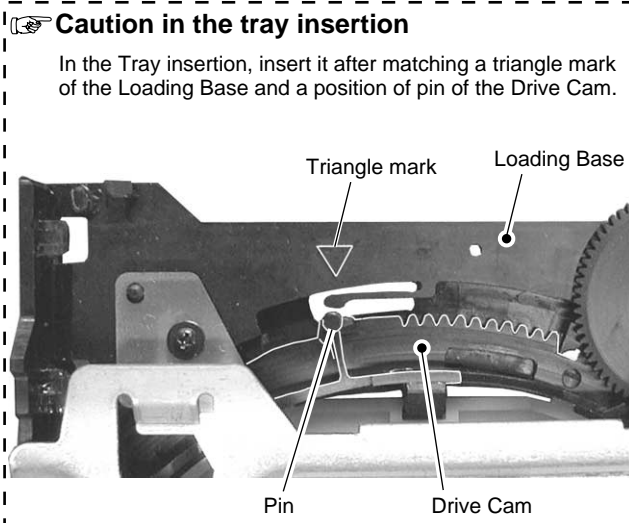

F

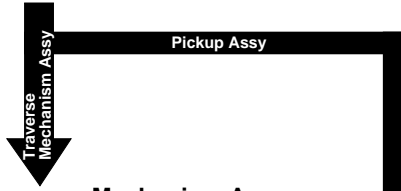

● When Removing The Traverse Mechanism Assy

- ⑫ Remove the Pickup Flexible Cable
 - ⑬ Unhook (×4)
 - ⑭ Remove the Traverse Mechanism Assy
-

Exchange

● When Removing The Pickup Assy

- ⑫ Remove the Pickup Flexible Cable.
-



- ⑬ Remove two Skew Screws and two Skew Springs.
- ⑭ Remove the Pickup Assy.

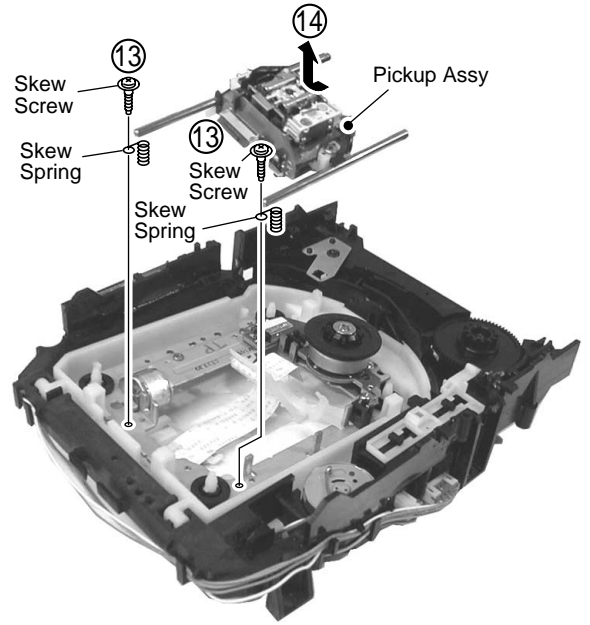

- ⑮ Remove two screws.

Cautions:
Screw is locked with Silicone adhesive.
Please lock it with Silicone adhesive when installs it.

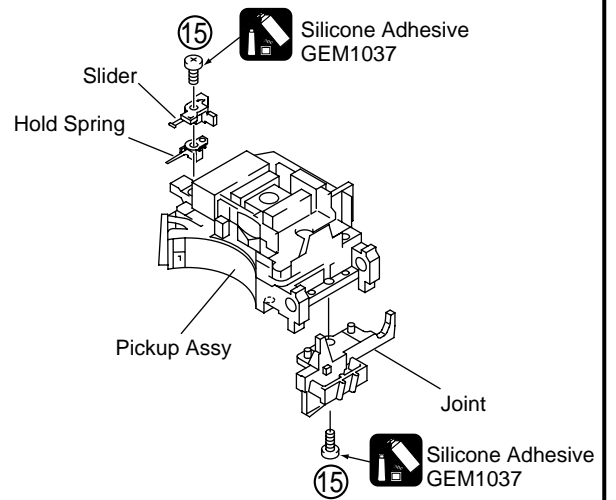

Exchange

A

Styling the Pickup Flexible Cable

- ① Fold a edge of lining part of the Pickup Flexible Cable.
- ② Insert the Pickup Flexible Cable in connector, and lock it surely.

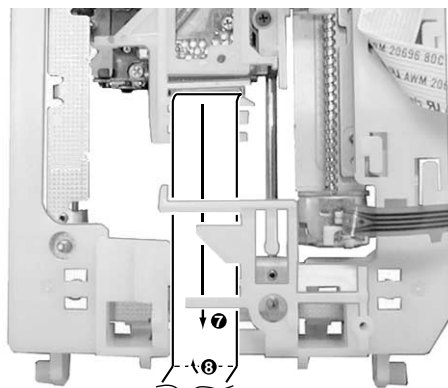
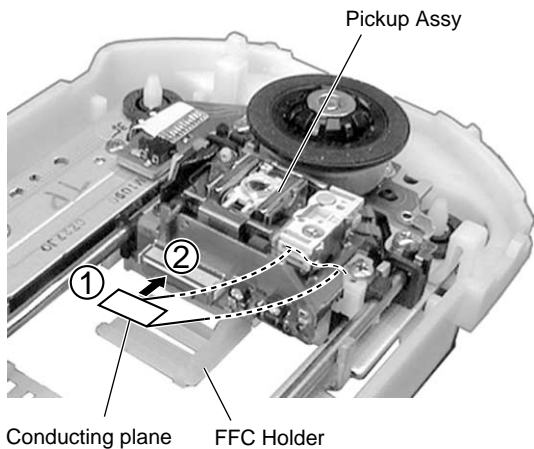

●Bottom View



C

- ③ Perform the styling as shown in figure below.

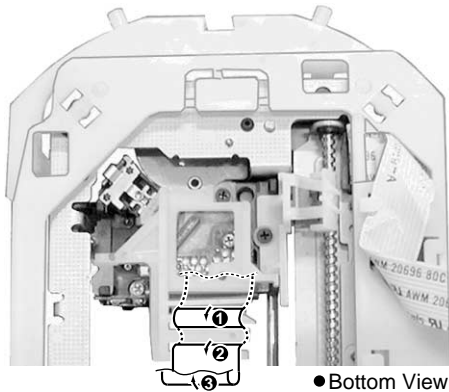

●Bottom View

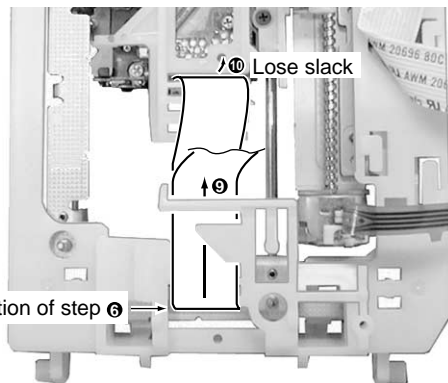

●Bottom View



E

Fold it at the position of reference line.

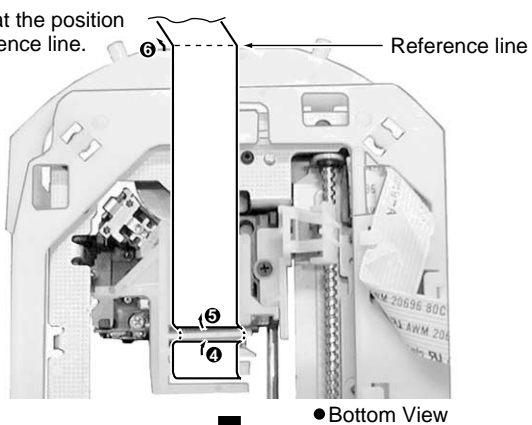

●Bottom View

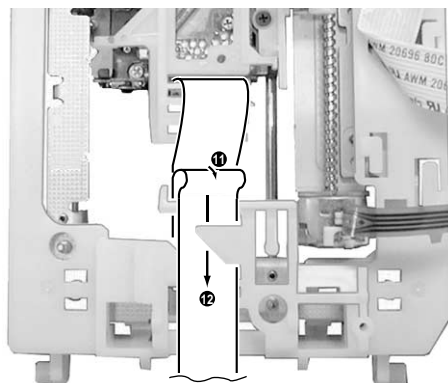

●Bottom View

F

7.2 IC

• The information shown in the list is basic information and may not correspond exactly to that shown in the schematic diagrams.

• List of IC

M56788AFP, MM1567AJ, STI5519AVB-B0C, PE5314B, L6315ATXXTY, BA6664FM, PCM1742KE

■ M56788AFP (FJMB ASSY : IC351)

• FTS Driver IC

● Block Diagram

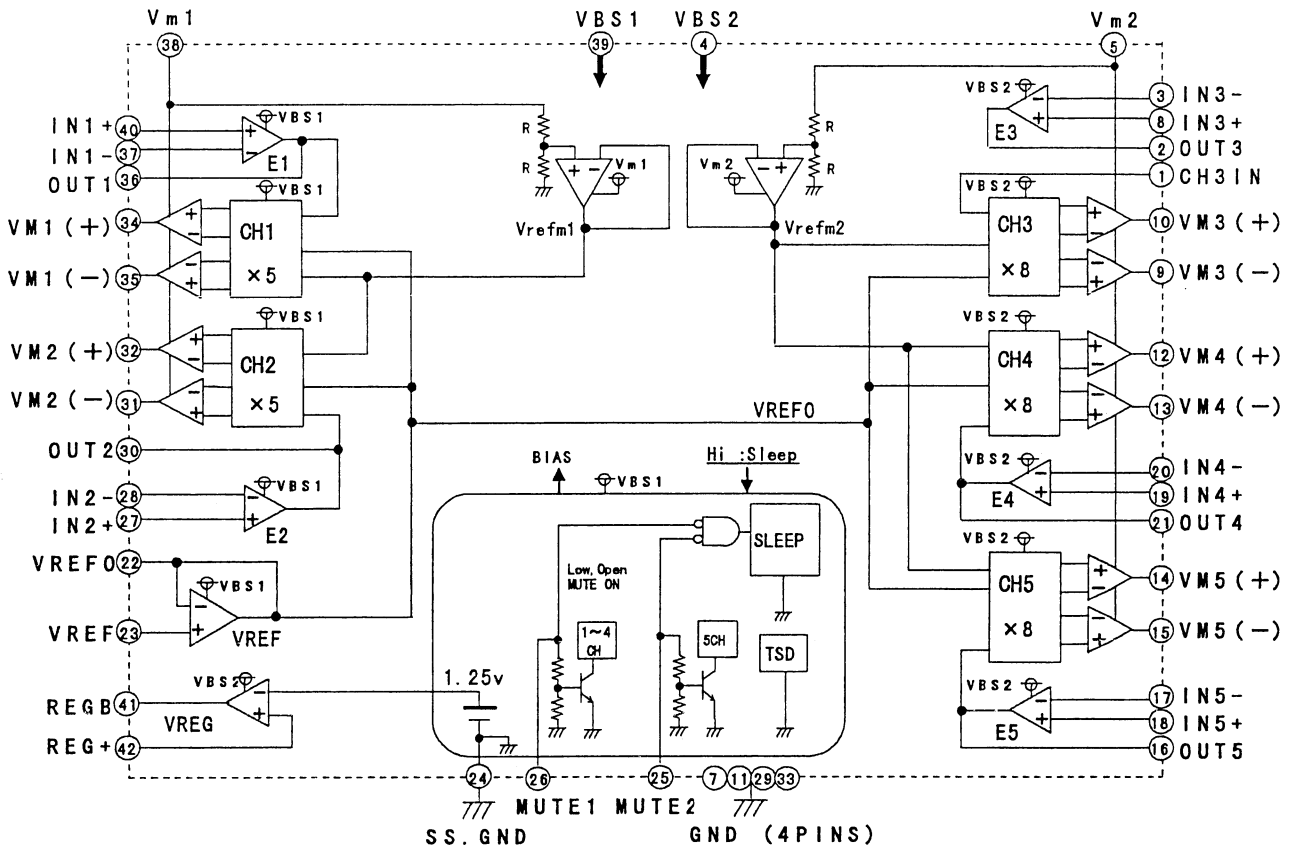

■ **MM1567AJ (FJMB ASSY : IC801)**

• DVD Video Amp IC

● **Block Diagram**

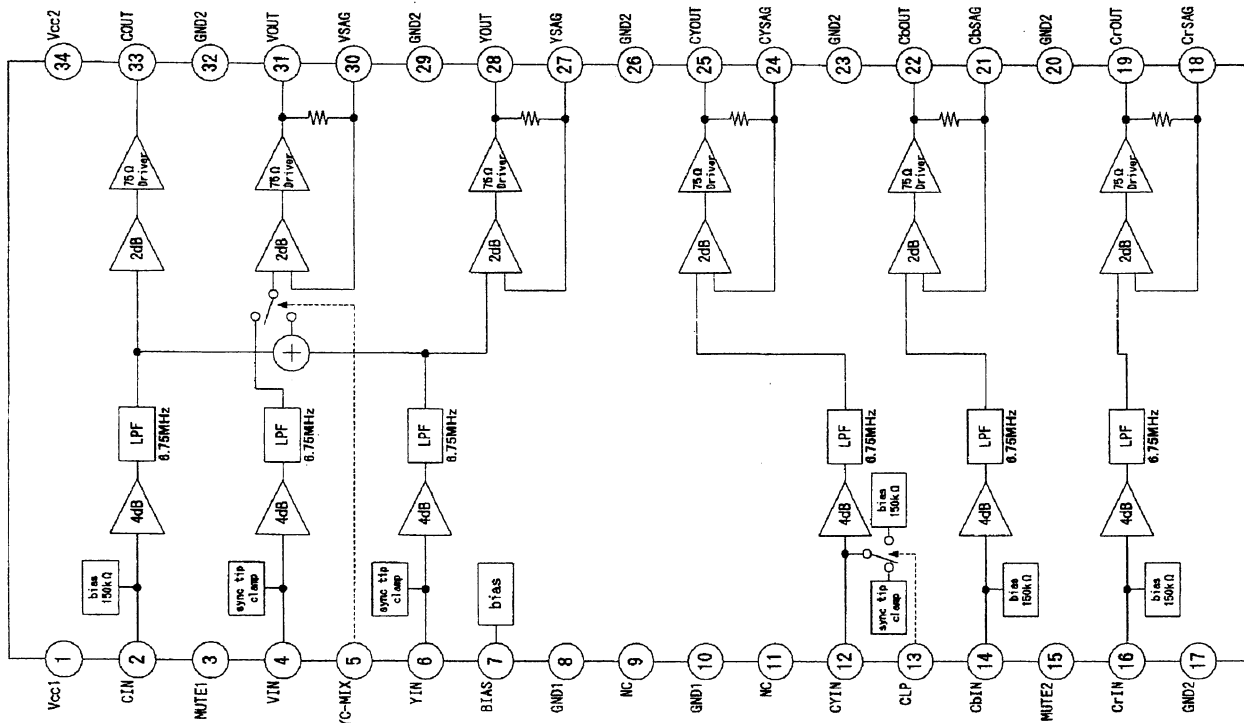

● **Pin Function**

| No. | Name | Pin Function | No. | Name | Pin Function |
|-----|--------|--------------------|-----|-------|----------------|
| 1 | VCC1 | VCC | 18 | CrOUT | Signal output |
| 2 | CIN | Croma input | 19 | CrSAG | SAG correction |
| 3 | MUTE1 | Mute select | 20 | GND2 | GND |
| 4 | VIN | Video input | 21 | CbOUT | Signal output |
| 5 | YC MIX | YC MIX select | 22 | CbSAG | SAG correction |
| 6 | YIN | Video input | 23 | GND2 | GND |
| 7 | BIAS | Bias | 24 | CYOUT | Signal output |
| 8 | GND1 | GND | 25 | CYSAG | SAG correction |
| 9 | NC | NC | 26 | GND2 | GND |
| 10 | GND1 | GND | 27 | YOUT | Signal output |
| 11 | NC | NC | 28 | YSAG | SAG correction |
| 12 | CYIN | Luminance input | 29 | GND2 | GND |
| 13 | CLP | Input clamp select | 30 | VOUT | Signal output |
| 14 | CbIN | Component input | 31 | VSAG | SAG correction |
| 15 | MUTE2 | Mute select | 32 | GND2 | GND |
| 16 | CrIN | Component input | 33 | COUT | Croma output |
| 17 | GND2 | GND | 34 | VCC2 | VCC |

STI5519AVB-B0C (FJMB ASSY : IC601)

• Back End IC

● Block Diagram

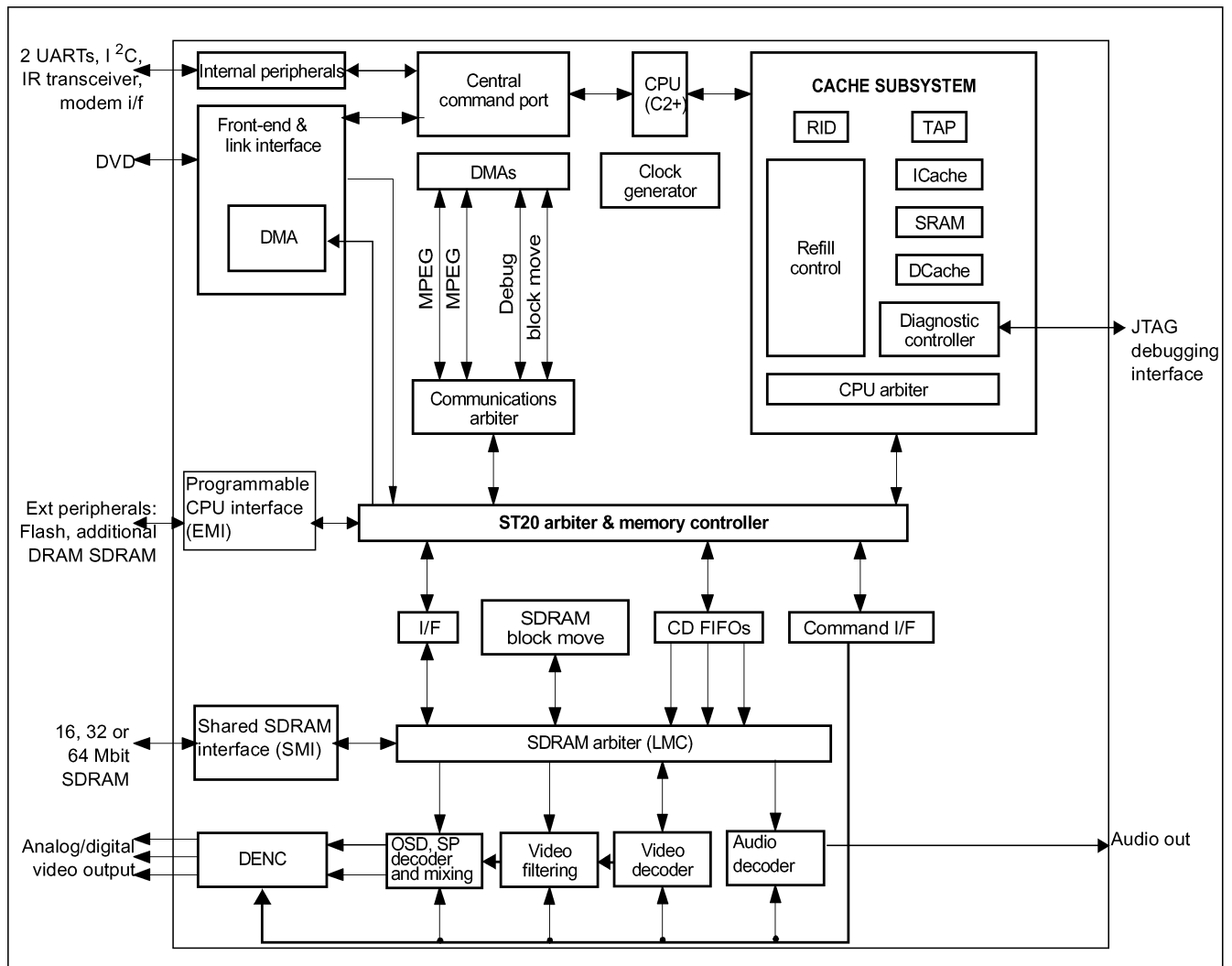

● Pin Function

| No. | Signal name | Dir. | Pin Functions |
|-----|--------------------|------|------------------------------------------------------------------------------------------------------------------------|
| 1 | FP_SO | OUT | Front Panel interface. (Soft) Serial transfer data output. |
| 2 | A_DATA3 | OUT | Reserved |
| 3 | XAMUTE | OUT | Analog audio output line muteing output 'L'. |
| 4 | VDD_3V3 | – | 3.3 V Power supply |
| 5 | VSS | – | Ground |
| 6 | AQE_XCS | OUT | Reserved Audio Quality Enhancer IC's chip-select output. |
| 7 | SQUEEZ | OUT | S-Video output S1/S2 control signal at squeeze output mode 'H'. |
| 8 | LETTER | OUT | S-Video output S1/S2 control signal & EURO(SCART) connector (FUNCTION SWITCHING) signal at letter-box output mode 'H'. |
| 9 | TRYPOS | OUT | In case of NOT carousel 5 disc changer, this port is N.C.(output) |
| | TRYPOS | IN | Carousel 5 Disc Changer only. Tray rotete puls input. Capture function can be used. |
| 10 | V_SEL1 | OUT | For EURO(SCART) connector (BLINKING) signal 'L' : RGB output disable 'H' : RGB output enable |
| 11 | RTS | OUT | UART(RS-232C) Request To Send signal output. |
| 12 | V_SEL2 | OUT | "For EURO(SCART) connector V/Y, R/C signal select 'L' : VRGB output = VRGB 'H' : VRGB output = YCGB |
| 13 | CTS | IN | UART(RS-232C) Clear To Send signal input. |
| 14 | VDD_2V5 | – | 2.5 V Power supply |
| 15 | VSS | – | Ground |
| 16 | FE_DATA | IN | Front-End L6315 stream interface. Serial data input. |
| 17 | FE_BCLK | IN | Front-End L6315 stream interface. Serial clock input. |
| 18 | FE_DVALID | IN | Front-End L6315 stream interface. Data valid flag input. |
| 19 | FE_SYNC | IN | Front-End L6315 stream interface. Serial synchronize flag input. |
| 20 | FE_EVALID | IN | Front-End L6315 stream interface. If STi5588 then RS-SPLIT error valid flag. |
| 21 | FE_ECCBST | IN | Front-End L6315 stream interface. If STi5588 then RS-SPLIT ECC Block Start flag. |
| 22 | TP- (VQE_XCS) | OUT | Reserved |
| 23 | VDD_RGB | – | RGB circuit 2.5 V Power supply |
| 24 | VSS_RGB | – | RGB circuit Ground |
| 25 | B_OUT | OUT | B / Cb |
| 26 | G_OUT | OUT | G / Y |
| 27 | RC_OUT | OUT | R / Cr |
| 28 | VREF_RGB | IN | RGB DAC reference |
| 29 | IREF_RGB | IN | RGB DAC electric current reference |
| 30 | VDD/YCC | – | YC circuit 2.5 V Power supply |
| 31 | VSS_YCC | – | YC circuit Ground |
| 32 | Y_OUT | OUT | Y |
| 33 | C_OUT | OUT | C |
| 34 | CV_OUT | OUT | CV |
| 35 | VREF_YC | IN | YCC DAC reference |

| No. | Signal name | Dir. | Pin Functions |
|-----|-------------|------|---------------------------------------------------------------------------------------------------------------------------|
| 36 | IREF_YC | IN | YCC DAC electric current reference |
| 37 | VDD_2V5 | – | 2.5 V Power supply |
| 38 | VSS | – | Ground |
| 39 | XAMUTE2 | OUT | In case of NOT Karaoke model, this port is N.C.(output). |
| | | | Karaoke model Before MIC mixing stage audio muteing output 'L'. |
| 40 | MIC_XON1 | OUT | In case of NOT Karaoke model, this port is N.C.(output). |
| | | | Karaoke model MIC mixing chanel control output. |
| 41 | MIC_XON2 | OUT | In case of NOT Karaoke model, this port is N.C.(output). |
| | | OUT | MIC_ON2 : MIC_ON1 : mode 0 0 : Don't use. 0 1 : Mix to Center Speaker 1 0 : Mix to main L/R channel 1 1 : OFF |
| | | | |
| 42 | TP-x | OUT | Reserved |
| 43 | CLAMP | OUT | In case of NOT carusel 5 disc changer, this port is N.C.(output) |
| | | IN | Carousel 5 Disc Chenger only. 'H' show disc clampe complete postion. |
| 44 | XUNCLAMP | OUT | In case of NOT carusel 5 disc changer, this port is N.C.(output) |
| | | IN | Carousel 5 Disc Chenger only. 'H' show disc un-clampe complete postion. |
| 45 | KDSP_RST | OUT | Reserved |
| 46 | 44X48 | OUT | In case of NOT Karaoke model, this port is N.C.(output) |
| | | | Karaoke model KARAOKE-DSP master clock 1/2 mode 'L'. |
| 47 | VDD3V3 | – | 3.3 V Power supply |
| 48 | VDD_PCM | – | 2.5 V Power supply |
| 49 | VSS_PCM | – | Ground |
| 50 | VSS | – | Ground |
| 51 | A_BCK | OUT | Audio DAC clock |
| 52 | A_DATA0 | OUT | Audio DAC Front L,R data |
| 53 | A_DATA1 | OUT | Audio DAC Center, LFE data |
| 54 | A_DATA2 | OUT | Audio DAC Surround L,R data |
| 55 | A_MCLK | OUT | Audio DAC Master clock |
| 56 | A_LRCK | OUT | Audio DAC L/R clock |
| 57 | DOUT | OUT | S/PDIF(IEC60958) digital audio output. |
| 58 | SMI_A4 | OUT | SMI SDRAM addresses |
| 59 | SMI_A5 | | |
| 60 | SMI_A6 | | |
| 61 | SMI_A7 | | |
| 62 | SMI_A8 | | |
| 63 | SMI_A9 | | |
| 64 | VDD_2V4 | – | 2.5 V Power supply |

A

B

C

D

E

F

| No. | Signal name | Dir. | Pin Functions |
|-----|-------------|------|----------------------------------------------------------------------------------------------------------------------|
| 65 | VSS | – | Ground |
| 66 | SMI_A3 | OUT | SMI SDRAM address |
| 67 | SMI_A2 | | |
| 68 | SMI_A1 | | |
| 69 | SMI_A0 | | |
| 70 | SMI_A10 | | |
| 71 | SMI_A11 | | |
| 72 | SMI_A12 | | |
| 73 | SMI_A13 | | |
| 74 | SMI_CS0 | OUT | SMI SDRAM chip select |
| 75 | SMI_CS1 | OUT | 2nd SMI SDRAM chip select |
| 76 | SMI_RAS | OUT | SMI SDRAM RAS |
| 77 | SMI_CAS | OUT | SMI SDRAM CAS |
| 78 | SMI_WE | OUT | SMI SDRAM Write Enable |
| 79 | SMI_DQML | OUT | SMI SDRAM Lower DQM |
| 80 | SMI_DQMU | OUT | SMI SDRAM Upper DQM |
| 81 | VDD_3V3 | – | 3.3 V Power supply |
| 82 | SMI_CLK | IN | SDRAM clock input. |
| 83 | VSS | – | Ground |
| 84 | SMI_D0 | I/O | SMI SDRAM data |
| 85 | SMI_D1 | | |
| 86 | SMI_D2 | | |
| 87 | SMI_D3 | | |
| 88 | SMI_D4 | | |
| 89 | SMI_D5 | | |
| 90 | SMI_D6 | | |
| 91 | SMI_D7 | | |
| 92 | SMI_D8 | | |
| 93 | SMI_D9 | | |
| 94 | VDD_2V5 | – | 2.5 V Power supply |
| 95 | SMI_CLK | OUT | SDRAM clock output. |
| 96 | VSS | – | Ground |
| 97 | SMI_D10 | I/O | SMI SDRAM data |
| 98 | SMI_D11 | | |
| 99 | SMI_D12 | | |
| 100 | SMI_D13 | | |
| 101 | SMI_D14 | | |
| 102 | SMI_D15 | | |
| 103 | KDSP_XCS | OUT | In case of NOT Karaoke model, this port is N.C.(output). Karaoke model Exteranal DSP chip select 'L'. |
| 104 | KDSP_THRU | OUT | In case of NOT Karaoke model, this port is N.C.(output). Karaoke model Exteranal DSP through pass mode 'L'. |

| No. | Signal name | Dir. | Pin Functions |
|-----|-------------|------|----------------------------------------------------------------------------------------------------------------------------------------------------------------------------|
| 105 | LFEON | OUT | Reserved for high-quality audio model's LFE control. |
| 106 | TP- | OUT | Not use. |
| 107 | VDD_3V3 | – | 3.3 V Power supply |
| 108 | VSS | – | Ground |
| 109 | TRST | | Diagnostic Controle Unit interface |
| 110 | TMS | | Diagnostic Controle Unit interface |
| 111 | TDTO | | Diagnostic Controle Unit interface |
| 112 | TDTI | | Diagnostic Controle Unit interface |
| 113 | TCK | | Diagnostic Controle Unit interface |
| 114 | ROTDRV | OUT | Carousel 5 disc changer model Tray rotation drive PWM output. |
| 115 | B_F_ROM | IN | Boot select 'L' : Boot from DCU. 'H' : Boot form ROM. |
| 116 | LOAD_DRV | OUT | Tray Open/Close drive PWM output (SINGL & CAROUSEL) |
| 117 | CPU_OE | OUT | 8M / 16M bits FLASH memory for firmware. |
| 118 | CPU_SDCK | OUT | 64M bits SDRAM for debugging firmware . |
| 119 | VDD_2V5 | – | 2.5 V Power supply |
| 120 | CLK27M | IN | Master 27MHz system clock input. |
| 121 | VSS | – | Ground |
| 122 | VDD_PLL | – | Clock PLL circuit 2.5 V Power supply |
| 123 | VSS_PLL | – | Clock PLL circuit Ground |
| 124 | RESET | IN | Power ON system RESET signal 'L' input. |
| 125 | DISC_SNS | IN | In case of NOT carusel 5 disc changer, this port is N.C.(input). Carousel 5 disc changer model Disc sense input. Pull up resistor is in another changer board. |
| 126 | FP_XRDY | IN | Front Panel interface. Hand-shake(request) input. |
| 127 | FE_INT | IN | Front-End L6315 Interrupt request input. |
| 128 | SD_DQML | OUT | Flash memory write enable 'L'. Debug SDRAM Lower DQM. |
| 129 | SD_DQMU | OUT | Debug SDRAM Upper DQM |
| 130 | SD_RXW | | Debug SDRAM Read/~Write |
| 131 | CPU_WAIT | OUT | CPU wait 'H' input |
| 132 | CE3 | OUT | Flash memory Chip Eenable 'L' |
| 133 | – | OUT | TP-x |
| 134 | – | OUT | TP-x |
| 135 | SD_XRAS | OUT | Debug SDRAM RAS 'L' |
| 136 | VDD_3V3 | – | 3.3V Vdd |
| 137 | VSS | – | GND |
| 138 | – | OUT | TP-x |
| 139 | SD_XCAS | OUT | Debug SDRAM CAS 'L' |
| 140 | SD_XCS | OUT | Debug SDRAM Chip Select 'L' |

A

B

C

D

E

F

| No. | Signal name | Dir. | Pin Functions |
|-----|-------------|------|----------------------------|
| 141 | CPU_D0 | I/O | FLASH, Debug SDRAM DATA |
| 142 | CPU_D1 | | |
| 143 | CPU_D2 | | |
| 144 | CPU_D3 | | |
| 145 | CPU_D4 | | |
| 146 | CPU_D5 | | |
| 147 | CPU_D6 | | |
| 148 | CPU_D7 | | |
| 149 | VDD_2V5 | – | 2.5 V Power supply |
| 150 | VSS | – | Ground |
| 151 | CPU_D8 | I/O | FLASH, Debug SDRAM DATA |
| 152 | CPU_D9 | | |
| 153 | CPU_D10 | | |
| 154 | CPU_D11 | | |
| 155 | CPU_D12 | | |
| 156 | CPU_D13 | | |
| 157 | CPU_D14 | | |
| 158 | CPU_D15 | | |
| 159 | VDD_3V3 | – | 3.3 V Power supply |
| 160 | VSS | – | Ground |
| 161 | CPU_A1 | OUT | FLASH, Debug SDRAM address |
| 162 | CPU_A2 | | |
| 163 | CPU_A3 | | |
| 164 | CPU_A4 | | |
| 165 | CPU_A5 | | |
| 166 | CPU_A6 | | |
| 167 | CPU_A7 | | |
| 168 | CPU_A8 | | |
| 169 | CPU_A9 | | |
| 170 | CPU_A10 | | |
| 171 | VDD_2V5 | – | 2.5 V Power supply |
| 172 | VSS | – | Ground |
| 173 | CPU_A11 | OUT | FLASH, Debug SDRAM address |
| 174 | CPU_A12 | | |
| 175 | CPU_A13 | | |
| 176 | CPU_A14 | | |
| 177 | CPU_A15 | | |
| 178 | CPU_A16 | | |
| 179 | CPU_A17 | | |
| 180 | CPU_A18 | | |
| 181 | CPU_A19 | | |
| 182 | CPU_A20 | | |
| 183 | CPU_A21 | | |
| 184 | VDD_3V3 | – | 3.3 V Power supply |

| No. | Signal name | Dir. | Pin Functions |
|-----|-------------|------|-------------------------------------------------------------------------------------------------------------------------------------------|
| 185 | VSS | – | Ground |
| 186 | XDRVMUTE | OUT | Motor driver muting signal 'L'. |
| 187 | RS_ERROR | IN | Front-End L6315 stream interface. If STi5588 then ECC Error flag. |
| 188 | I2C_SEL | OUT | Reserved (Front-End L6315 command interface.) (‘L’ : I2C bus connect to I2C_DMA) (‘H’ : I2C bus connect to I2C_COMAND) |
| 189 | DAC_SCK | OUT | Audio DAC serial control clock output. |
| 190 | DAC_SO | OUT | Audio DAC serial control data output. |
| 191 | DAC_XCS0 | OUT | Audio DAC serial control chip select output. |
| 192 | DAC_XCS1 | OUT | Reserved (Audio DAC serial control chip select output. For addition DAC) |
| 193 | 6CH_MODE | OUT | In case of NOT 6ch audio output model, this port is N.C.(output). 6ch audio output model Audio quality up control signal output. |
| 194 | SDA | SDA | Front-End L6315 command interfase I2C bus serial data line. |
| 195 | SCL | SCL | Front-End L6315 command interfase I2C bus serial clock line. |
| 196 | FE_RST | OUT | Front-End L6315 Hard reset output. |
| 197 | TXD | TXD | UART(RS-232C) data output |
| 198 | VDD_2V5 | | 2.5 V Power supply |
| 199 | VSS | IN | Ground |
| 200 | RXD | RXD | UART(RS-232C) data input |
| 201 | TP-x | OUT | Reserved |
| 202 | TRIGIN | – | Diagnostic Controle Unit interface |
| 203 | TRIGOUT | – | Diagnostic Controle Unit interface |
| 204 | OPEN | IN | 'H' show tray loading "OPEN" complete position. |
| 205 | XCLOSE | IN | 'H' show tray loading "CLOSE" complete position. |
| 206 | FP_ACK | OUT | Front Panel interface. Hand-shake (acknowledge) output. |
| 207 | FP_SCK | OUT | Front Panel interface. (Soft) Serial transfer clock output. |
| 208 | FP_SI | IN | Front Panel interface. (Soft) Serial transfer data input. |

■ PE5314B (FJMB ASSY : IC11)

• FL Controller

● Pin Function

| No. | Signal name | Dir. | Pin Functions |
|-----|---------------|------|-------------------------------------------------------------------------------------------------------------------------------------------------------------------------------------------------------|
| 1 | VDD1 | – | Positive Power Supply (3.3 V) |
| 2 | VSS1 | – | Ground Potential |
| 3 | X1 | IN | Crystal Connection for Main System Clock Oscillation |
| 4 | X2 | – | |
| 5 | IC | – | Internally Connected (Directly connect to VSS1) |
| 6 | RESET | IN | Reset Input |
| 7 | SCK1 | IN | Serial Clock Input of Serial Interface |
| 8 | SI1 | IN | Serial Data Input of Serial Interface |
| 9 | SO1 | OUT | Serial Data Output of Serial Interface |
| 10 | XRDY | OUT | Hand-shake (Ready) Output of Serial Interface |
| 11 | POWER ON | OUT | Power Control Output |
| 12 | RESET OUT | OUT | System Reset Output |
| 13 | RESERVE OUT | OUT | Reserved (NC on this model) |
| 14 | LED8 | OUT | LED Port 8 (NC on this model) |
| 15 | HALT | IN | Halt Port "NC" : Use Halt Mode |
| 16 | ACK | IN | Hand-shake (Acknowledge) Input of Serial Interface (Not used on this model) |
| 17 | SEL IR | IN | Remote Control Input (Timer input of 8-bit remote control timer) |
| 18 | Avss | – | Ground Potential for A/D Converter |
| 19 | MS1 | IN | Destination (of player) Select (Analog Input for A/D Converter) |
| 20 | ECHO VR | IN | Karaoke model : Echo Volume Input No Karaoke model : NC (Analog Input for A/D Converter) |
| 21 | KEY1 | IN | Key Input 1 (Analog input for A/D converter) |
| 22 | KEY0 | IN | Key Input 0 (Analog input for A/D converter) |
| 23 | VSS0 | – | Ground Potential to Ports |
| 24 | AVDD | – | Analog Power/Reference Voltage Input to A/D Converter (3.3 V) |
| 25 | VDD0 | – | Positive Power Supply to Ports (3.3 V) |
| 26 | MS0_2 | IN | Model (of player) Select (Set with a combination of this 3 ports) |
| 27 | MS0_1 | | |
| 28 | MS0_0 | | |
| 29 | LED7 | OUT | LED Port 7 (NC on this model) |
| 30 | LED(STAND BY) | OUT | Stand By LED Port (NC on this model) |
| 31 | NC | – | NC |
| 32 | TES | IN | "H" : No System Reset mode "L" : General mode |
| 33 | OEM | IN | "H" : OEM Model "L" : Pioneer Model |
| 34 | MIC IN | IN | Detection of Microphone "H" : Microphone connected |
| 35 | CHECKER | IN | "H" : Checker Mode "L" : General mode |
| 36 | ON POWER | IN | "H" : Primary Power Switch Model "L" : Secondary Power Switch Model |
| 37 | FL SET2 | IN | FL-Controller Mode Select FL SET1 / 2 = "H" / "H" : DV-353 (This model) FL SET1 / 2 = "H" / "L" : Other model FL SET1 / 2 = "L" / "H" : Other model FL SET1 / 2 = "L" / "L" : Other model |
| 38 | FL SET1 | | |
| 39 | TEST2 | OUT | Test Port |
| 40 | LED6 | OUT | LED Port 6 (NC on this model) |

| No. | Signal name | Dir. | Pin Function |
|-----|-------------|------|---------------------------------------------------------------|
| 41 | LED5 | OUT | LED Port 5 (NC on this model) |
| 42 | LED4 | | LED Port 4 (NC on this model) |
| 43 | LED3 | | LED Port 3 (NC on this model) |
| 44 | LED2 | | LED Port 2 (NC on this model) |
| 45 | LED1 | | LED Port 1 (NC on this model) |
| 46 | LED0 | | LED Port 0 (NC on this model) |
| 47 | TEST1 | OUT | Test Port |
| 48 | TEST0 | | |
| 49 | NC | - | NC |
| 50 | NC | | |
| 51 | P16 | OUT | FIP Segment 16 Output |
| 52 | P15 | OUT | FIP Segment 15 Output |
| 53 | NC | - | NC |
| 54 | P14 | OUT | FIP Segment 14 Output |
| 55 | P13 | | FIP Segment 13 Output |
| 56 | P12 | | FIP Segment 12 Output |
| 57 | P11 | | FIP Segment 11 Output |
| 58 | P10 | | FIP Segment 10 Output |
| 59 | VDD2 | - | Positive Power Supply to FIP Controller/Driver (3.3 V) |
| 60 | VLOAD | - | Pull-down Resistor Connection of FIP Controller/Driver (-28V) |
| 61 | P9 | OUT | FIP Segment 9 Output |
| 62 | P8 | | FIP Segment 8 Output |
| 63 | P7 | | FIP Segment 7 Output |
| 64 | P6 | | FIP Segment 6 Output |
| 65 | P5 | | FIP Segment 5 Output |
| 66 | P4 | | FIP Segment 4 Output |
| 67 | P3 | | FIP Segment 3 Output |
| 68 | P2 | | FIP Segment 2 Output |
| 69 | P1 | | FIP Segment 1 Output |
| 70 | G11 | OUT | FIP Grid 11 Output |
| 71 | G10 | | FIP Grid 10 Output |
| 72 | G9 | | FIP Grid 9 Output |
| 73 | G8 | | FIP Grid 8 Output |
| 74 | G7 | | FIP Grid 7 Output |
| 75 | G6 | | FIP Grid 6 Output |
| 76 | G5 | | FIP Grid 5 Output |
| 77 | G4 | | FIP Grid 4 Output |
| 78 | G3 | | FIP Grid 3 Output |
| 79 | G2 | | FIP Grid 2 Output |
| 80 | G1 | | FIP Grid 1 Output |

L6315ATXXTY (FJMB ASSY : IC301)

• Front End IC

● Block Diagram

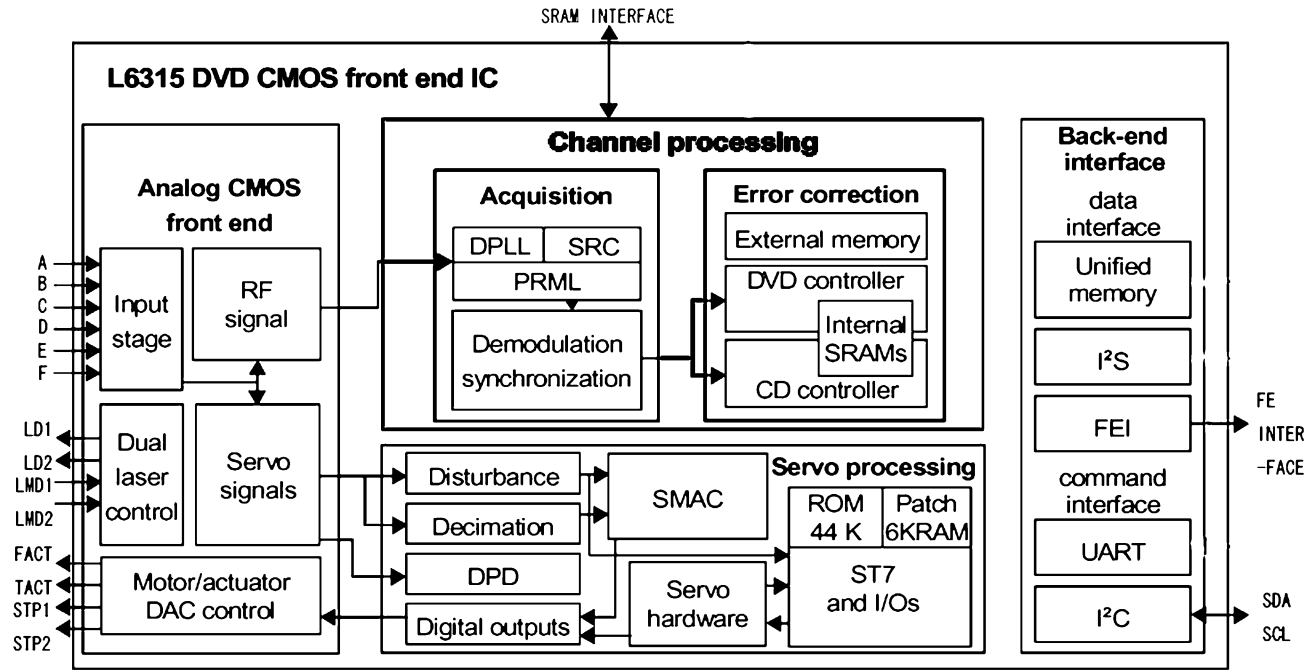

● Pin Function

| No. | Name | Type | Description |
|-----|----------------|----------------|------------------------------------------|
| 1 | IREF | Analog input | bandgap filtering input |
| 2 | GNDAI | Analog ground | analog power supply ground |
| 3 | RFSACD | Analog output | RF output for SA-CD support |
| 4 | RFIN | Analog input | RF path data input (after AC coupling) |
| 5 | RFOUT | Analog output | RF path data output (before AC coupling) |
| 6 | VCCA18 | Analog supply | input stage power supply |
| 7 | TST_ADC | Analog output | RF path analog test pin |
| 8 | TST_SLICE | Analog output | PM analog test pin |
| 9 | TST_PM | Analog output | PM analog test pin |
| 10 | A | Analog input | input stages laser diode A |
| 11 | GNDMN | Analog ground | input stages ground main |
| 12 | B | Analog input | input stages laser diode B |
| 13 | VCC33MN | Analog supply | input stages 3.3 V misc. |
| 14 | REFD | Analog output | reference voltage for pickup |
| 15 | VCC18IS | Analog supply | input stages 1.8 V main |
| 16 | D | Analog input | input stages laser diode D |
| 17 | VCCA18IS | Analog supply | input stages 1.8 V misc. |
| 18 | C | Analog input | input stages laser diode C |
| 19 | VCC33IS | Analog supply | input stages 3.3 V misc. |
| 20 | GNDAIS | Analog ground | input stages ground misc. |
| 21 | VCC33SD | Analog supply | input stages 3.3 V side |
| 22 | VCC18SD | Analog supply | input stages 1.8 V side |
| 23 | GNDSD | Analog ground | input stages ground side |
| 24 | F | Analog input | input stages laser diode F |
| 25 | E | Analog input | input stages laser diode E |
| 26 | VSHIELIS | Analog ground | IS shield |
| 27 | VDDADC | Analog supply | ADC digital power supply |
| 28 | VSSADC | Analog ground | ADC digital ground supply |
| 29 | VCCADC | Analog supply | ADC analog power supply |
| 30 | GNDADC | Analog ground | ADC analog ground supply |
| 31 | VSHIELDADC | Analog ground | ADC shield |
| 32 | NC | - | - |
| 33 | BOOT_MODE | Digital input | Boot mode |
| 34 | VSS | Digital ground | VSS I/O |
| 35 | VDD3 | Digital supply | VDD I/O (3.3 V) |
| 36 | PC[0] (NC) | Digital I/O | - |
| 37 | PC[1] (PS) | Digital I/O | Driver IC power save |
| 38 | PC[2] (FG) | Digital I/O | FG pulse input |
| 39 | PC[3] (SB) | Digital I/O | Spindle short brake |
| 40 | PC[4] (SLDPOS) | Digital I/O | Slider position input |

A

B

C

D

E

F

| No. | Name | Type | Description |
|-----|--------------------|----------------|-----------------------------------|
| 41 | PC[5] (VROFST) | Digital I/O | VREF offset adjustment (stand-by) |
| 42 | PC[6] (SPDL_PDM) | Digital I/O | Spindle drive out |
| 43 | PC[7] (OEICG) | Digital I/O | OEIC gain sw |
| 44 | VSS | Digital ground | VSS core |
| 45 | VDD3S | Digital supply | VDD core |
| 46 | VSS_SPL | Digital ground | VSS I/O |
| 47 | RAM_DQM | Digital output | SDRAM DQM |
| 48 | RAM_WEN | Digital output | RAM write enable |
| 49 | RAM_CASN / Sradr14 | Digital output | SRAM address |
| 50 | RAM_RASN / Sradr15 | Digital output | SRAM address |
| 51 | RAM_A[13] | Digital output | SRAM address |
| 52 | RAM_A[12] | Digital output | SRAM address |
| 53 | RAM_A[11] | Digital output | SRAM address |
| 54 | RAM_A[10] | Digital output | SRAM address |
| 55 | RAM_A[0] | Digital output | SRAM address |
| 56 | RAM_A[1] | Digital output | SRAM address |
| 57 | RAM_A[2] | Digital output | SRAM address |
| 58 | RAM_A[3] | Digital output | SRAM address |
| 59 | RAM_A[4] | Digital output | SRAM address |
| 60 | RAM_A[5] | Digital output | SRAM address |
| 61 | RAM_A[6] | Digital output | SRAM address |
| 62 | RAM_A[7] | Digital output | SRAM address |
| 63 | RAM_A[8] | Digital output | SRAM address |
| 64 | RAM_A[9] | Digital output | SRAM address |
| 65 | RAM_CLK / Sradr16 | Digital output | SRAM address |
| 66 | VDD_SPL | Digital supply | VDD I/O |
| 67 | VDD3 | Digital supply | VDD I/O |
| 68 | VSS | Digital ground | VSS I/O |
| 69 | RAM_DQ[0] | Digital I/O | SRAM data |
| 70 | RAM_DQ[1] | Digital I/O | SRAM data |
| 71 | RAM_DQ[2] | Digital I/O | SRAM data |
| 72 | RAM_DQ[3] | Digital I/O | SRAM data |
| 73 | RAM_DQ[4] | Digital I/O | SRAM data |
| 74 | RAM_DQ[5] | Digital I/O | SRAM data |
| 75 | RAM_DQ[6] | Digital I/O | SRAM data |
| 76 | RAM_DQ[7] | Digital I/O | SRAM data |
| 77 | VDD3S | Digital supply | VDD core |
| 78 | VSS | Digital ground | VSS core |
| 79 | OUT_REQ | Reserved | Must be set to ground |
| 80 | OUT_ERR | Digital output | Output interface |

| No. | Name | Type | Description |
|-----|-------------------------|----------------|--------------------------|
| 81 | OUT_SYNC | Digital output | Output interface |
| 82 | OUT_DVALID | Digital output | Output interface |
| 83 | OUT_CLK | Digital output | Output interface |
| 84 | OUT_DATA[0] (FE_DATA) | Digital output | Output interface |
| 85 | OUT_DATA[1] (FE_EVALID) | Digital output | Output interface: BW com |
| 86 | OUT_DATA[2] (FE_ECCBST) | Digital output | Output interface: BW com |
| 87 | OUT_DATA[3] | Digital output | Reserved |
| 88 | OUT_DATA[4] | Digital output | Reserved |
| 89 | OUT_DATA[5] | Digital output | Reserved |
| 90 | OUT_DATA[6] | Digital output | Reserved |
| 91 | OUT_DATA[7] | Digital output | Reserved |
| 92 | VDD3 | Digital supply | VDD I/O |
| 93 | VSS | Digital ground | VSS I/O |
| 94 | PE[0] (FE_INIT) | Digital I/O | FE initialize input |
| 95 | PE[1] (NC) | Digital I/O | - |
| 96 | PE[2] (DMA) | Digital I/O | DMA input |
| 97 | PE[3] (SCL) | Digital I/O | I2C clock input |
| 98 | PE[4] (SDA) | Digital I/O | I2C data input |
| 99 | PD[0] (NC) | Digital I/O | - |
| 100 | PD[1] (NC) | Digital I/O | - |
| 101 | PD[2] (NC) | Digital I/O | - |
| 102 | PD[3] (NC) | Digital I/O | - |
| 103 | PD[4] (NC) | Digital I/O | - |
| 104 | PD[5] (NC) | Digital I/O | - |
| 105 | PD[6] (NC) | Digital I/O | - |
| 106 | PD[7] (NC) | Digital I/O | - |
| 107 | VDD3 | Digital supply | VDD I/O |
| 108 | VSS | Digital ground | VSS I/O |
| 109 | VPP_TEST | Digital input | Test input |
| 110 | VCCD_BYP | Digital supply | VDD core |
| 111 | VCCD_OUT | - | No voltage to be applied |
| 112 | VSS | Digital ground | VSS core |
| 113 | VDD3S | Digital supply | VDD core |
| 114 | VSS | Digital ground | VSS I/O |
| 115 | VDD3 | Digital supply | VDD I/O |
| 116 | RESET_IN | Digital input | Global reset signal |
| 117 | VCC18DAC | Analog supply | DAC analog power supply |
| 118 | STEPPER1 | Analog output | DAC spindle motor |
| 119 | STEPPER2 | Analog output | DAC sled motor |
| 120 | REFEXT | Analog input | DAC external reference |

A

B

C

D

| No. | Name | Type | Description |
|-----|---------|----------------|----------------------------------------|
| 121 | REFGND | Analog ground | DAC analog ground supply |
| 122 | REFDAC | Analog output | DAC reference voltage |
| 123 | FACT | Analog output | DAC focus actuator |
| 124 | TACT | Digital output | DAC tracking actuator |
| 125 | GNDDAC | Analog ground | DAC analog ground supply |
| 126 | NC | - | - |
| 127 | VCCA33 | Analog supply | DAC analog power supply |
| 128 | NC | - | - |
| 129 | GNDPLL | Analog ground | PM analog ground supply |
| 130 | PLLOFF | Analog input | PM reference disable PLL |
| 131 | FREOUT | Analog output | PM reference frequency out |
| 132 | FREIN | Analog input | PM reference frequency in |
| 133 | VCCPLL | Analog supply | PM analog power supply |
| 134 | SREG1 | Analog output | External bipolar base |
| 135 | VCCR33 | Analog supply | Analog power supply for regulator |
| 136 | SREG2 | Analog output | External bipolar base |
| 137 | LD1 | Analog output | Laser control laser diode 1 |
| 138 | LD2 | Analog output | Laser control laser diode 2 |
| 139 | VCCA33 | Analog supply | Analog power supply for input stages + |
| 140 | LCREF | Analog output | Laser control DAC reference |
| 141 | LMD1 | Analog input | Laser control monitor diode 1 |
| 142 | LMD2 | Analog input | Laser control monitor diode 2 |
| 143 | GNDL | Analog ground | Laser control detector ground sup |
| 144 | VBGFILT | Analog input | Bandgap filtering input |

E

F

■ BA6664FM (FJMB ASSY : IC251)

• Spindle Driver

● Block Diagram

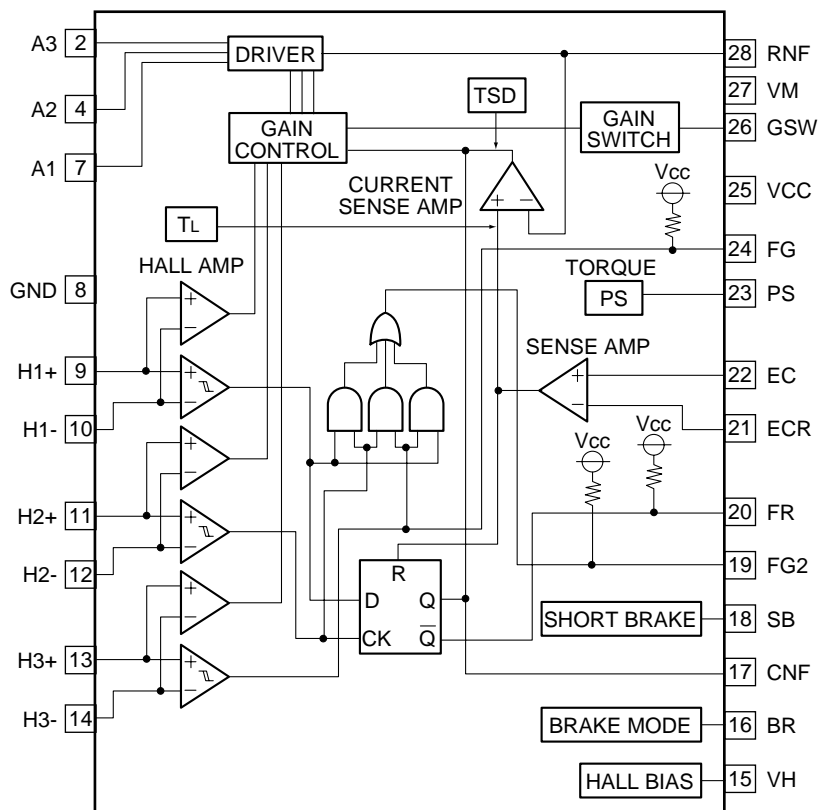

● Pin Function

| No. | Pin Name | Pin Function | No. | Pin Name | Pin Function |
|-----|----------|------------------------|-----|----------|------------------------------------------------------|
| 1 | N.C. | N.C. | 16 | BR | Brake mode switching pin |
| 2 | A3 | Output pin | 17 | CNF | Capacitor connection pin for phase compensation |
| 3 | N.C. | N.C. | 18 | SB | Short brake pin |
| 4 | A2 | Output pin | 19 | FG2 | FG 3-phase mix signal output pin |
| 5 | N.C. | N.C. | 20 | FR | Rotation detecting pin |
| 6 | N.C. | N.C. | 21 | ECR | Control reference pin of output voltage |
| 7 | A1 | Output pin | 22 | EC | Output voltage control pin |
| 8 | GND | GND pin | 23 | PS | Power save pin |
| 9 | H1+ | Hall signal input pins | 24 | FG | FG signal output pin |
| 10 | H1- | | 25 | VCC | Power supply pin |
| 11 | H2+ | | 26 | GSW | Gain switching pin |
| 12 | H2- | | 27 | VM | Motor power pin |
| 13 | H3+ | | 28 | RNF | Resistor connection pin for output current detection |
| 14 | H3- | | FIN | FIN | GND |
| 15 | VH | Hall bias pin | | | |

PCM1742KE (FJMB ASSY : IC711)

• D/A Converter

● Pin Arrangement



● Pin Function

| No. | Nmae | I/O | Pin Function |
|-----|-------------|-----|-------------------------------------------------------------------|
| 1 | BCK | I | Audio data bit clock input |
| 2 | DATA | I | Audio data digital input |
| 3 | LRCK | I | L-channel and R-channel Audio data latch enable input |
| 4 | DGND | - | Digital ground |
| 5 | VDD | - | Digital power supply +3.3V |
| 6 | VCC | - | Analog power supply +5V |
| 7 | VOUTL | O | Analog output for L-channel |
| 8 | VOUTR | O | Analog output for R-channel |
| 9 | AGND | - | Analog ground |
| 10 | VCOM | - | Common voltage decoupling |
| 11 | ZEROR/ZEROA | O | Zero flag output for R-channel / Zero flag output for L/R-channel |
| 12 | ZEROL/NA | O | Zero flag output for L-channel / No assign |
| 13 | MD | I | Mode control data input |
| 14 | MC | I | Mode control clock input |
| 15 | ML | I | Mode control latch input |
| 16 | SCK | I | System clock input |

● Block Diagram

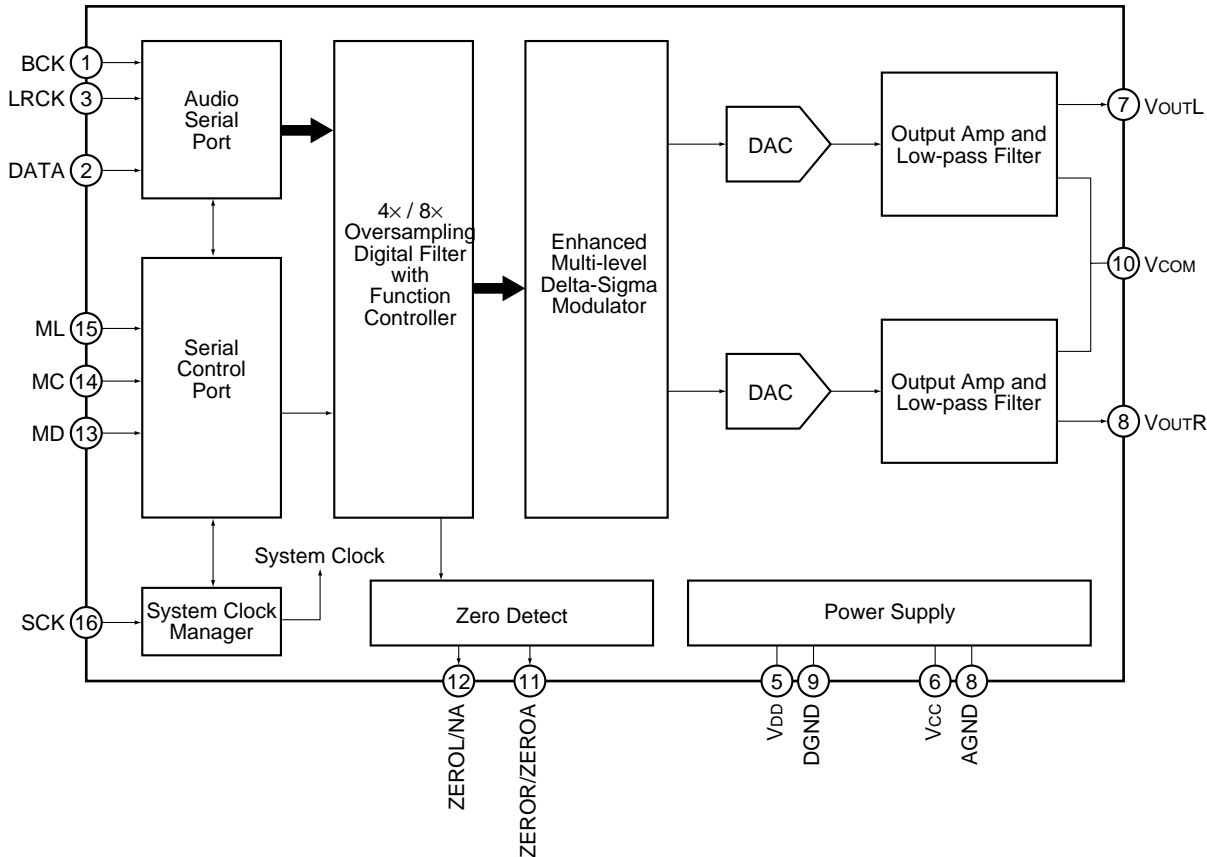

7.3 CLEANING



Before shipping out the product, be sure to clean the following positions by using the prescribed cleaning tools:

| Position to be cleaned | Cleaning tools |
|------------------------|-------------------------------------------------------|
| Pickup lenses | Cleaning liquid : GEM1004 Cleaning paper : GED-008 |

A

B

C

D

E

F

8. PANEL FACILITIES

Front panel

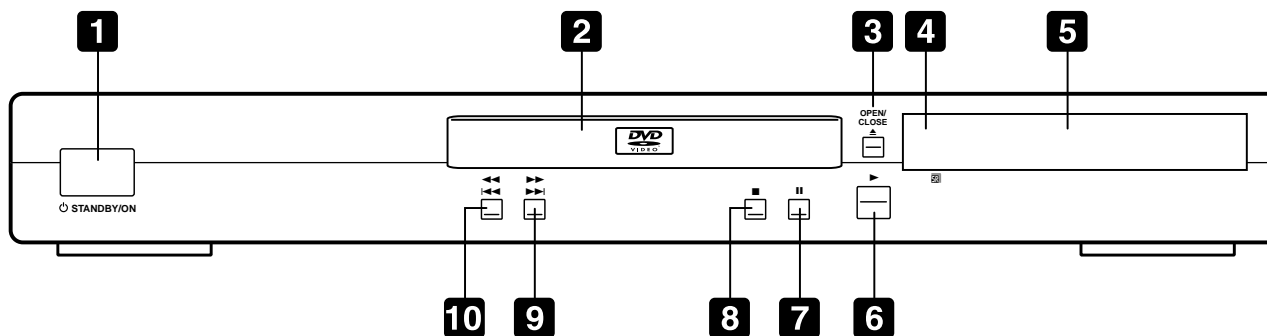

1 **STANDBY/ON**

Press to switch the player on or into standby

2 **Disc tray**

3 **OPEN/CLOSE**

Press to open or close the disc tray

4 **Remote control sensor**

The remote control has a range of up to about 7m

5 **Display**

6

Press to start or resume playback

7

Press to pause playback. Press again to restart

8

Press to stop the disc (you can resume playback by pressing (play))

9

- Press and hold for fast forward scanning
- Press to jump to the next chapter or track

10

- Press and hold for fast reverse scanning
- Press to jump back to the beginning of the current chapter or track, then to previous chapters/tracks

Display

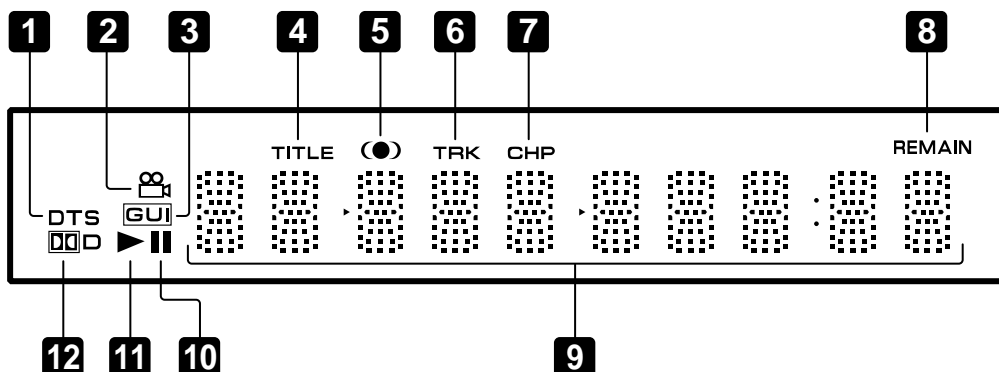

1 DTS

Lights when a DTS soundtrack is playing

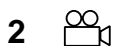

2 Lights during multi-angle scenes on a DVD disc

3 GUI (Graphical User Interface)

Lights when a menu is displayed on-screen

4 TITLE

Indicates that the character display is showing a DVD title number



5 Lights when DTS/TruSurround is active

6 TRK

Indicates that the character display is showing a CD or Video CD track number

7 CHP

Indicates that the character display is showing a DVD chapter number

8 REMAIN

Lights when the character display is showing the time or number of tracks/titles/chapters remaining

9 Character display

10 ||

Lights when a disc is paused



11 Lights when a disc is playing

12 DD

Lights when a Dolby Digital soundtrack is playing

Rear panel connections

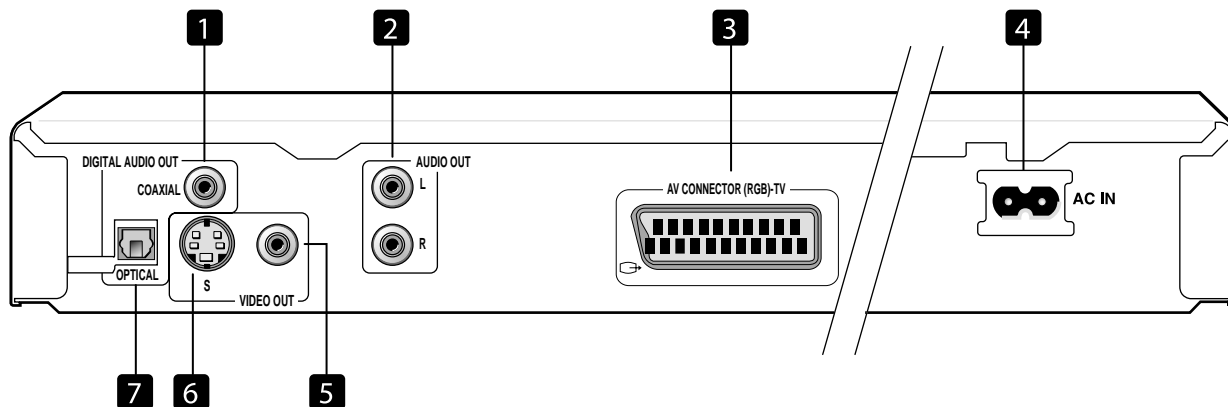

When connecting this player up to your TV, AV receiver or other components, make sure that all components are switched off and unplugged.

1 DIGITAL AUDIO OUT – COAXIAL

This is a digital audio output for connection to a PCM, Dolby Digital, DTS and/or MPEG-compatible AV receiver that has a coaxial digital input.

Connect using a commercially available coaxial digital audio cable.

2 AUDIO OUT L / R

This pair of analog audio outputs connects to your TV, AV receiver or stereo system. Even if you are connecting up one of the digital outputs, we still recommend you connect these jacks.

Use the supplied audio/video cable when connecting these jacks. Match the colors of the jacks and cables for correct stereo sound.

3 AV CONNECTOR (RGB) - TV

This is a combined audio and video output for connection to a TV that has a SCART input. Connect using a SCART cable. The type of video output can be switched to suit your TV.

4 AC IN

Connect the supplied power cord here, then plug into a power outlet.

5 VIDEO OUT

This is a standard video output that you can connect to your TV or AV receiver using the supplied audio/video cable.

6 S (S-Video output)

This is an S-video output that you can use instead of the video output described in 5 above.

7 DIGITAL AUDIO OUT - OPTICAL

This is a digital audio output for connection to a PCM, Dolby Digital, DTS and/or MPEG-compatible AV receiver that has an optical digital input.

Connect using a commercially available optical digital audio cable.

Remote control

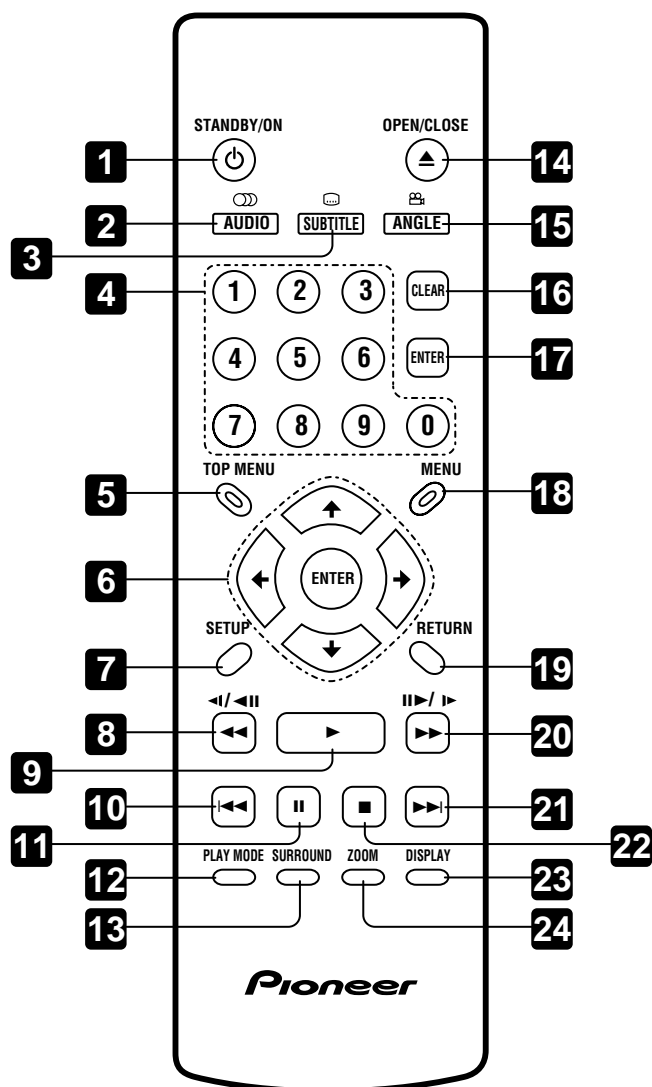

1 STANDBY/ON

Press to switch the player on or into standby

2 AUDIO

Press to select the audio channel or language

3 SUBTITLE

Press to select a subtitle display

4 Number buttons

5 TOP MENU

Press to display the top menu of a DVD disc

6 ENTER & cursor control buttons

Use to navigate on-screen displays and menus. Press **ENTER** to select an option or execute a command

7 SETUP

Press to display (or exit) the on-screen display

8 ◀◀ and ◀/◀◀

Use for reverse slow motion playback, frame reverse and reverse scanning.

9 ▶

Press to start or resume playback

10 I◀◀

Press to jump to the beginning of the current chapter or track, then to previous chapters/tracks

11 ||

Press to pause playback; press again to restart

12 PLAY MODE

Press to display the Play Mode menu
(You can also get to the Play Mode menu
by pressing **SETUP** and selecting
Play Mode)

13 SURROUND

Press to activate/switch off **DOLBY**/TruSurround

14 OPEN/CLOSE

Press to open or close the disc tray

15 ANGLE

Press to change the camera angle during
DVD multi-angle scene playback

16 CLEAR

Press to clear a numeric entry

17 ENTER

Use to select menu options, etc. (works
exactly the same as the **ENTER** button in 6
above)

18 MENU

Press to display a DVD disc menu, or the
Disc Navigator if a CD, Video CD or MP3 disc
is loaded

19 RETURN

Press to return to a previous menu screen

20 PAUSE and STILL/PLAY

Use for forward slow motion playback, frame
advance and forward scanning.

21 NEXT

Press to jump to the next chapter or track

22 STOP

Press to stop the disc (you can resume
playback by pressing **▶** (play))

23 DISPLAY

Press to display information about the disc
playing

24 ZOOM

Press to change the zoom level