



SP-46A / 500PA

PA Bass Speaker

Blue line
serie **IMG**
STAGELINE

KEY FEATURES

Product reference : 10.3420

PA Bass-Midrange Speakers for professional applications. Blue lacquered aluminium diecast basket with very stable paper cone with water-repellent coating. Highest efficiency, very high pulse power capability and gold-plated push terminals. Super PA bass speaker, 2.000W_{MAX}, 8Ω, Very great linear excursion, additional ventilation behind the centering spider, suitable for deep and powerful bass applications and subwoofer applications in very compact bass-reflex cabinets.

A professional bass speaker for every application.



TECHNICAL SPECIFICATION

Impedance (Z)	8Ω	DC resistance (Re)	6.4Ω
Resonant frequency (fs)	32Hz	Voice coil induct. (Le)	1.7mH
Max. frequency range	f3-2,500Hz	Voice coil former	glass fibre
Rec. crossover freq. (fmax.)	900Hz	Voice coil diameter	99mm
Music power	2,000WMAX	DC resistance (Re)	6.4Ω
Power rating (P)	500WRMS	Voice coil winding height	20mm
SPL (1W/1m)	99dB	Air gap height	8mm
Suspension compl. (Cms)	0.15mm/N	Linear excursion (XMAX)	±6mm
Moving mass (Mms)	168g	Eff. cone area (Sd)	1,180cm ²
Mech. resistance (Rms)	5.1kg/s	Volume displacement (Vd)	708cm ³
Mech. Q factor (Qms)	6.65	Force factor (BxL)	29.1Tm
Electr. Q factor (Qes)	0.26	Reference efficiency (No)	3.5%
Total Q factor (Qts)	0.25	Magnet diameter	210mm
Equivalent volume (Vas)	285 l	Magnet weight	125oz.

DIMENSION DRAWINGS

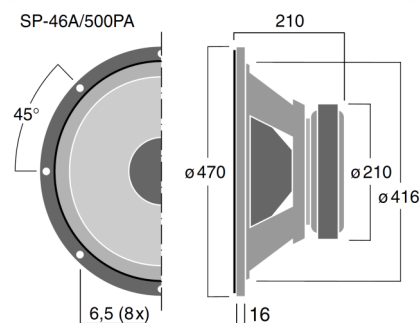

MOUNTING INFORMATION

Mounting cutout	Ø 416mm
Mounting depth	210mm
Dimensions	Ø 470mm
Weight	13kg
Rec. net cabinet volume	approx.110

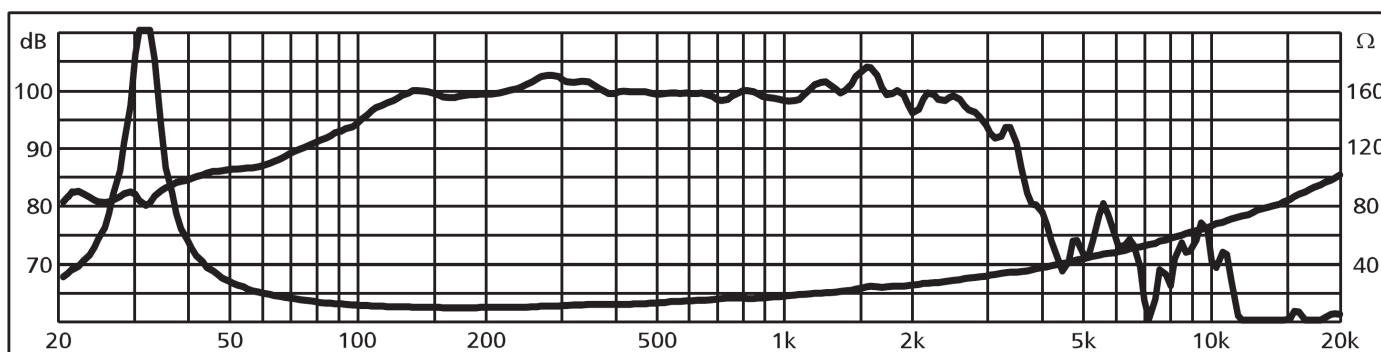

MONACOR INTERNATIONAL GmbH & Co. KG

Zum Falsch 36— 28307 Bremen, Germany—Tel: +49 421 4865-0—Fax: +49 421 4884-15—E-Mail: info@monacor.com—Web: http://monacor.com

SPECIMEN By www.phd-audio.fr