



# SP-30 PATC

## PA Full range Speaker

Blue line  
serie **IMG**  
STAGELINE

### KEY FEATURES

Product reference : 10.4240

- ◆ PA full range speaker
- ◆ High-quality speaker
- ◆ Robust diecast basket
- ◆ Linear frequency response
- ◆ Exceptional wide bandwidth
- ◆ Special twin cone design with stabilising dust cap
- ◆ At an optimum low distortion



Excellent for monitoring applications or full range PA applications

### TECHNICAL SPECIFICATION

Impedance (Z)	8 Ω	Equivalent volume (Vas)	107 l
Frequency range	f3-15,000 Hz	DC resistance (Re)	5.2 Ω
Resonant frequency (fs)	47 Hz	Force factor (BxL)	14.03 Tm
Rec. crossov. frequ. (fmax.)	(12 dB/oct.)	Voice coil induct. (Le)	0.7 mH
Power rating	200 WRMS	Voice coil diameter	50 mm
Peak music power output	400 WMAX	Voice coil former	KSV
Sensitivity	99 dB/W/m	Linear excursion (XMAX)	±2 mm
Suspension compl. (Cms)	0.29 mm/N	Eff. cone area (Sd)	510 cm <sup>2</sup>
Moving mass (Mms)	38 g	Magnet weight	1.4 kg
Mech. Q factor (Qms)	3.69	Magnet diameter	Ø 155 mm
Electr. Q factor (Qes)	0.30	Admiss. ambient temp.	0-40 °C
Total Q factor (Qts)	0.28	Weight	4.65 kg

### DIMENSION DRAWINGS

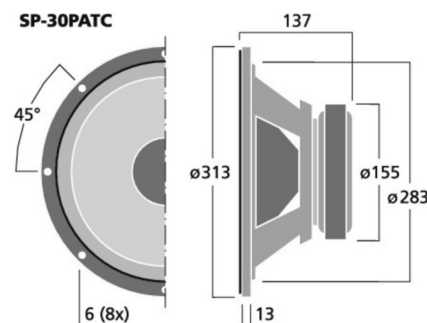

### MOUNTING INFORMATION

Mounting cutout	Ø 283 mm
Mounting depth 1	4 mm
Outside diameter	Ø 313 mm

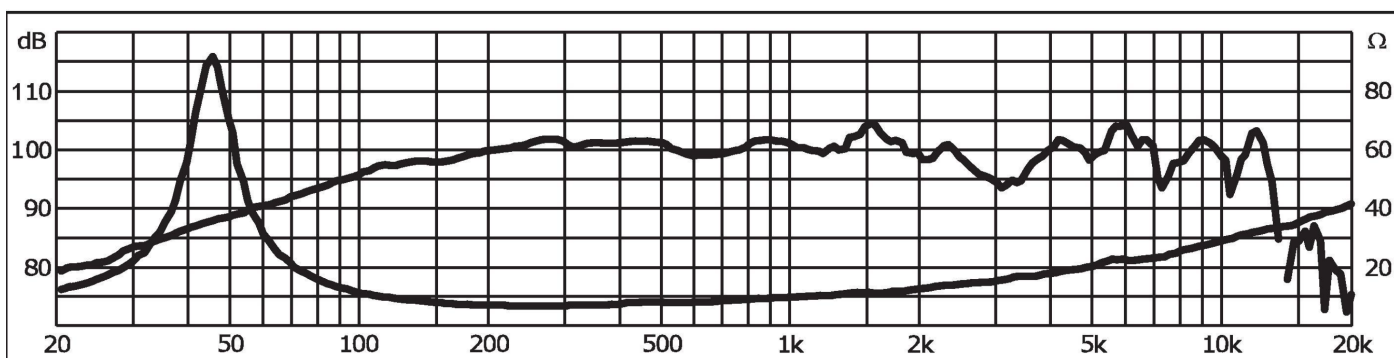

MONACOR INTERNATIONAL GmbH & Co. KG

Zum Falsch 36— 28307 Bremen, Germany—Tel: +49 421 4865-0—Fax: +49 421 4884-15—E-Mail: info@monacor.com—Web: http://monacor.com

SPECIMEN By [www.phd-audio.fr](http://www.phd-audio.fr)